



Model 7
Power Wheel[®]
Planetary Gear Drive



CONTENTS

Introduction	3
Model 7 Wheel Drives - Double Reduction	4-5
Model 7 Wheel Drives w/A2 Series Integral Parking Brake - Double Reduction	6-7
Model 7 Shaft Output Drives - Double Reduction	8-9
Model 7 Shaft Output Drives w/A2 Series Integral Parking Brake - Double Reduction	10-11
Model 7 Shaft Input/Shaft Output Drives - Double Reduction	12-13
Model 7 Output Shafts and Other Options	14
Lubrication Data / Warranty Information	15

AuburnGear® Power Wheel® Final Drives

INTRODUCTION

Auburn Gear is your reliable source for a variety of power transfer products. This catalog features the Model 7 family of **Power Wheel®** Planetary Gear Drives. Other models of **Power Wheels** are also available; for a complete offering, contact Auburn Gear.

We also offer planetary gear kits and spin resistant differentials. We offer you services for design, engineering, prototype support and full testing and production capabilities. Product applications include aerial lift, agricultural, automotive, construction, forestry, industrial and marine. Auburn Gear offers you quality and reliability backed by more than 50 years of experience.

Greater Design Flexibility

Power Wheel® planetary drives allow greater flexibility than conventional power train systems and often eliminate the need for components such as drive shafts, axles and chain drives. The many models and styles offered meet a wide range of mobile and industrial application requirements. Single, double and triple reduction ratios can be furnished. In addition, they can be supplied with a variety of motor mounts and inputs which allow them to be used with most makes of hydraulic motors.

High Efficiency and Compact Design

Providing 94 to 98% power transfer efficiency, Power Wheel® planetary drives are significantly more efficient than many other types of drives, including differential design planetaries. The rugged, compact design of these drives saves space and provides for long service life.

All models can be furnished with parking brakes. Auburn Gear has designed integral A2 Series parking brakes in Models 5, 6, 6B, 7, 8, 8B and 9. These units provide a very compact planetary drive/parking brake package which is particularly useful in applications where space is limited.

Responsive Performance

Power Wheel® drives deliver the power you require for smooth operation and precise control. These units are also fully reversible. Reverse power is easily obtained by reversing rotation of the input. For vehicle applications, the positive traction provided by individually powered wheels results in superior maneuverability and improved ground clearance than conventional drive systems.

Auburn Gear Power Wheel drives can be an efficient solution for any application where you need to increase torque or reduce speed to achieve usable power. Let Power Wheel® planetary drives help you put power in its place.

MODEL 7 FEATURES

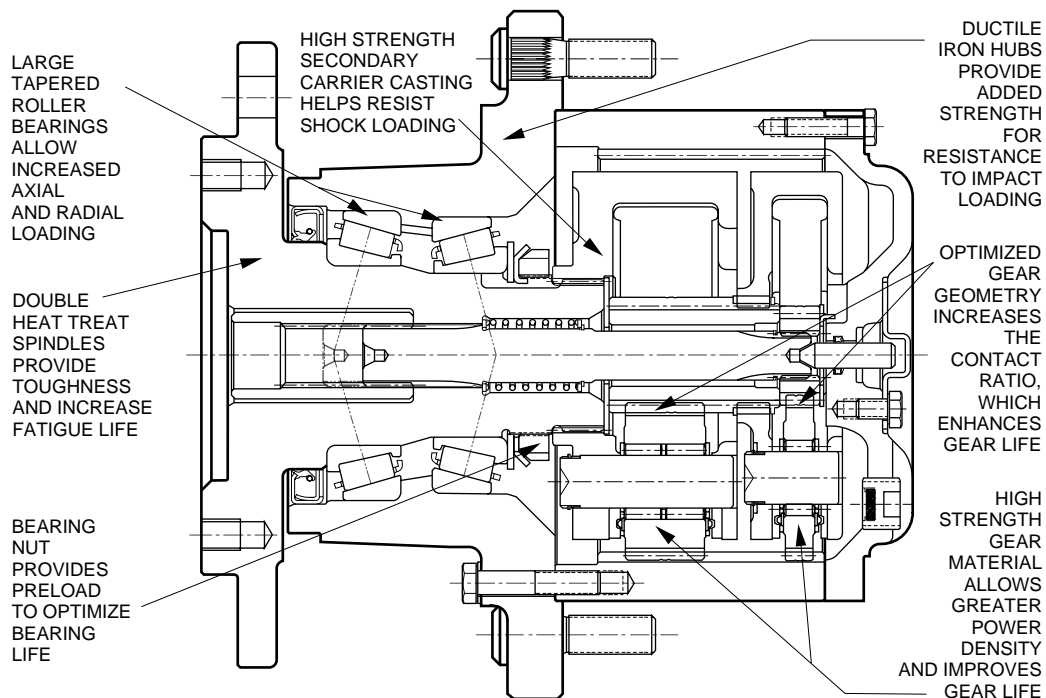

Model 7 Wheel Drives Double Reduction

GENERAL SPECIFICATIONS

Max. intermittent output torque ¹	70,000 lb-in (7,910 Nm)	Approximate Weight	120 lbs (54 kg)
Max. input speed	5,000 RPM	Oil capacity	31 oz (920 cc)

For Lubrication Data, see Page 15

¹ Depending on the duty cycle and the nature of the application, a normal continuous output torque of 1/3 to 1/2 of the Maximum Intermittent should yield satisfactory *Power Wheel* life. Also, due to the Model 7's unique combination of small physical size and high torque potential, thermal capacity may become a limiting factor. Customer testing and application analysis is strongly recommended.

Dimensions given in: INCHES (mm)

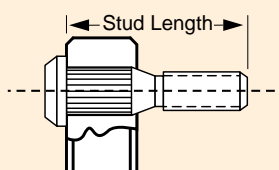
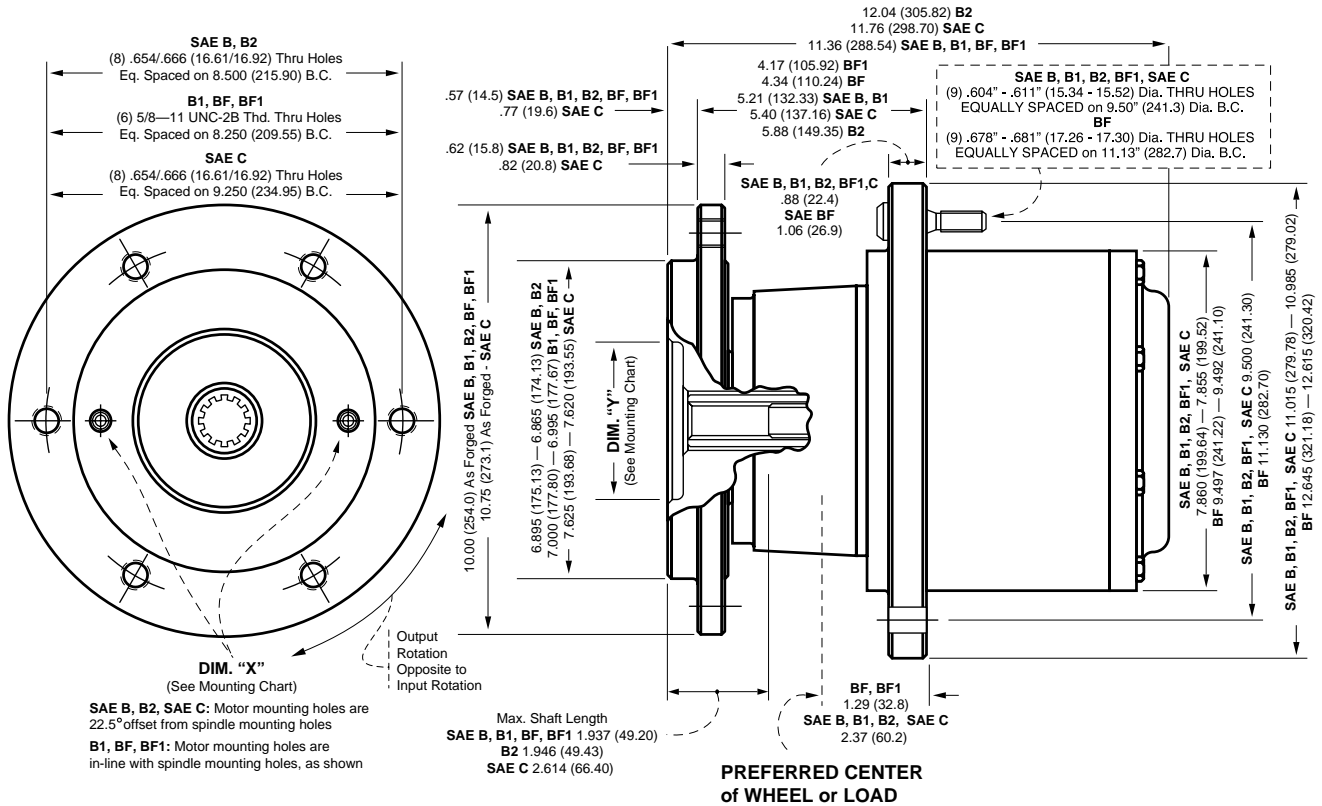

Wheel Stud – Detail

Note that the stud lengths shown in the feature chart represent the total length of the stud under the head.

**NON-POWERED UNITS
ARE ALSO AVAILABLE**
Contact Auburn Gear for Information

FEATURE CHART: MODEL 7 WHEEL DRIVES DOUBLE REDUCTION

OPTIONS	DESCRIPTION	MAKE ALL SELECTIONS WITHIN ONE COLUMN		ORDER CODES	USE OPTION ORDER CODES TO BUILD ORDER NUMBER		
MOTOR PILOT/HUB	SAE B	•		7WB	7WB		
	B1	•		7WB1			
	B2	•		7WB2			
	BF	•		7WBF			
	BF1	•		7WBF1			
	SAE C		•	7WC			
INPUT SPLINE	13T. 16/32	•		13		13	
	14T. 12/24		•	14			
	15T. 16/32	•		15			
RATIO OPTIONS	13.06:1	•		13			
	15.88:1	•		15			
	17.94:1	•		17			
	19.62:1	•		19			
	21.74:1	•		21			
	24.53:1	•		24		24	
	28.37:1	•		28			
	32.79:1	•		32			
WHEEL STUDS	1/2" by 2.50	•	•	5			
	9/16" by 2.75	•	•	7		7	
	5/8" by 2.37	•	•	8			
	NONE	•	•	0			
SPECIAL FEATURES	Boot Seal	•	•	Z			Z
	Quick Disconnect	•	•	Q			
	Oil Plugs/Spindle Side	•	•	P			
Select desired characteristics from chart, note correct order codes, and order using sample format shown at right:					7WB 13 24 7 Z		

BOLDFACE INDICATES REGULAR VOLUME PRODUCED ITEMS WITH BEST AVAILABILITY.

MODEL 7 BEARING LIFE CURVE Based On
LIFE = 3,000 Hours B10 SPEED = 100 RPM Output

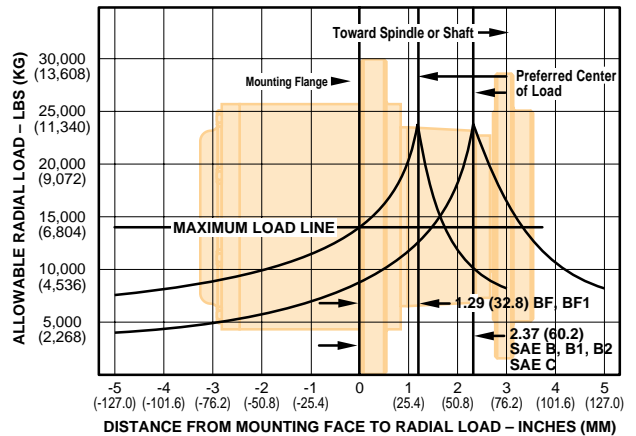

NOTE:

These curves are supplied as a design guide and apply to resultant radial load only. They indicate the importance of maintaining wheel position over the bearing center.

For actual analysis, applications should be reviewed by Auburn Gear Engineering using data supplied on Application Data Form.

MOTOR MOUNTING CHART

DIMENSION "X"	DIM. "Y"
SAE B, B1, B2, BF, BF1 (2) – .500 (12.70) -13 UNC. 2B Thd Holes Equally Spaced on 5.750 (146.05) B. C.*	Ø 4.001 - 4.006 (101.62 - 101.75)
SAE C (4) – .500 (12.70) -13 UNC. 2B Thd Holes Equally Spaced on 6.375 (161.93) B. C.*	Ø 5.001 - 5.006 (127.02 - 127.15)

*"O" RING OR GASKET REQUIRED (Not Supplied by Auburn Gear)
"O" RING SIZES: SAE "B" 2–155, SAE "C" 2–159

NOTE:

The data presented in this catalog is for general information and preliminary layout purposes only. Auburn Gear, through its policy of continual improvement, reserves the right to update its products; therefore, the information presented is subject to change. For specific application and/or dimensional information, contact Auburn Gear.

BEARING LOAD, LIFE AND SPEED RELATIONSHIPS

$$LF = \frac{SF \times R}{R'}$$

R = Allowable resultant load for given location from mounting flange

R' = Anticipated load at location from mounting flange

LF = Life Factor from table (see below)

SF = Speed Factor from table (see below)

OUTPUT SPEED (RPM)	SF	LF	BEARING HOURS B-10 LIFE
5	2.456	.584	500
10	1.994	.719	1000
20	1.620	.812	1500
30	1.435	.886	2000
40	1.316	.947	2500
50	1.231	1.000	3000
60	1.165	1.047	3500
70	1.113	1.090	4000
80	1.069	1.130	4500
90	1.032	1.166	5000
100	1.000	1.231	6000
200	.812	1.289	7000
300	.719	1.342	8000
400	.659	1.390	9000
500	.617	1.435	10000

CAUTION: The same torsional loading constraints used in the driving mode must be used in the braking mode when braking through the **Power Wheel** drive gear set.

Model 7 Wheel Drives Double Reduction with A2 Series Integral Parking Brake

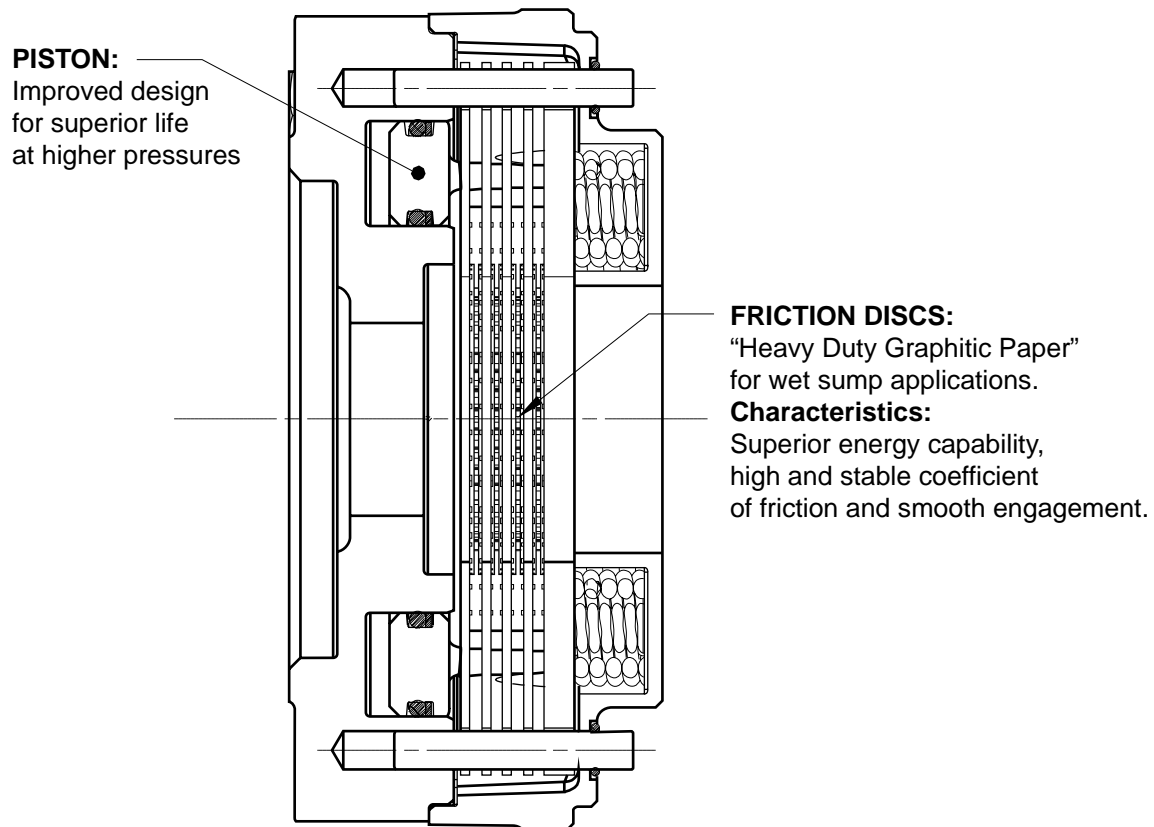

GENERAL A2 SERIES DATA:

1. Maximum operating pressure is 3,000 psi (206.4 Bar). Pressure spikes or surges not to exceed 3,500 psi (240.8 Bar). Surge pressure in excess of 3,500 psi (240.8 Bar) caused by spikes in the hydraulic system could shorten brake life and must be avoided.
2. Use only SAE grade 8 mounting bolts and torque to 80-90 lb. ft. (108-122 N-m) for motor mounting.
3. **PRECAUTION:** Bench testing may cause distortion of components or bolt failure. Mounting bolts must be used for supplemental clamping.
4. Minimum Release Pressure is defined as the hydraulic pressure required to obtain full running clearance.
5. Cubic Inch Displacement is the volume of oil required to release the brake piston 1.0 in³ (16.4cc) for a new brake and 2.0 in³ (32.8cc) for a worn brake pack.

Model 7 Wheel Drives Double Reduction with A2 Series Integral Parking Brake

Max. intermittent output torque ¹	70,000 lb-in (7,910 Nm)	Approximate Weight	140 lbs (64 kg)
Max. input speed ²	2,000 RPM	Oil capacity	36 oz (1070 cc)

For Lubrication Data, see Page 15

¹ Depending on the duty cycle and the nature of the application, a normal continuous output torque of $\frac{1}{3}$ to $\frac{1}{2}$ of the Maximum Intermittent should yield satisfactory *Power Wheel* life. Also, due to the Model 7's unique combination of small physical size and high torque potential, thermal capacity may become a limiting factor.

² For input speed between 2,000 and 3,600 rpm please contact Auburn Gear for duty cycle analysis. Customer testing and application analysis is strongly recommended.

Dimensions given in: INCHES (mm)

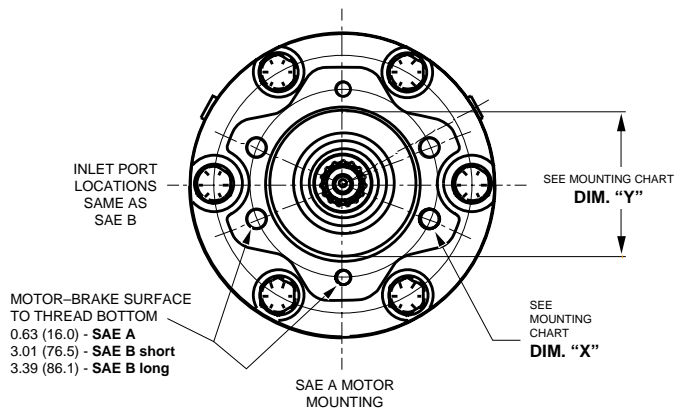
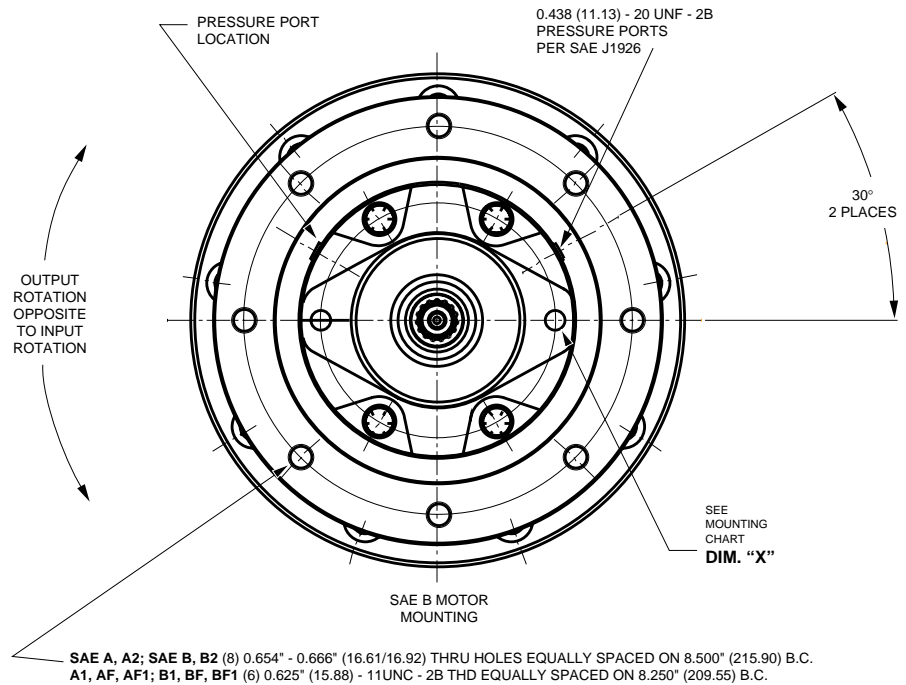

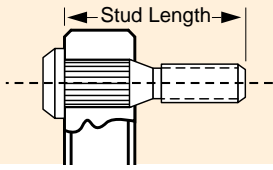

Wheel Stud – Detail

Note that the stud lengths shown in the feature chart represent the total length of the stud under the head.

**NON-POWERED UNITS
ARE ALSO AVAILABLE**
Contact Auburn Gear for Information

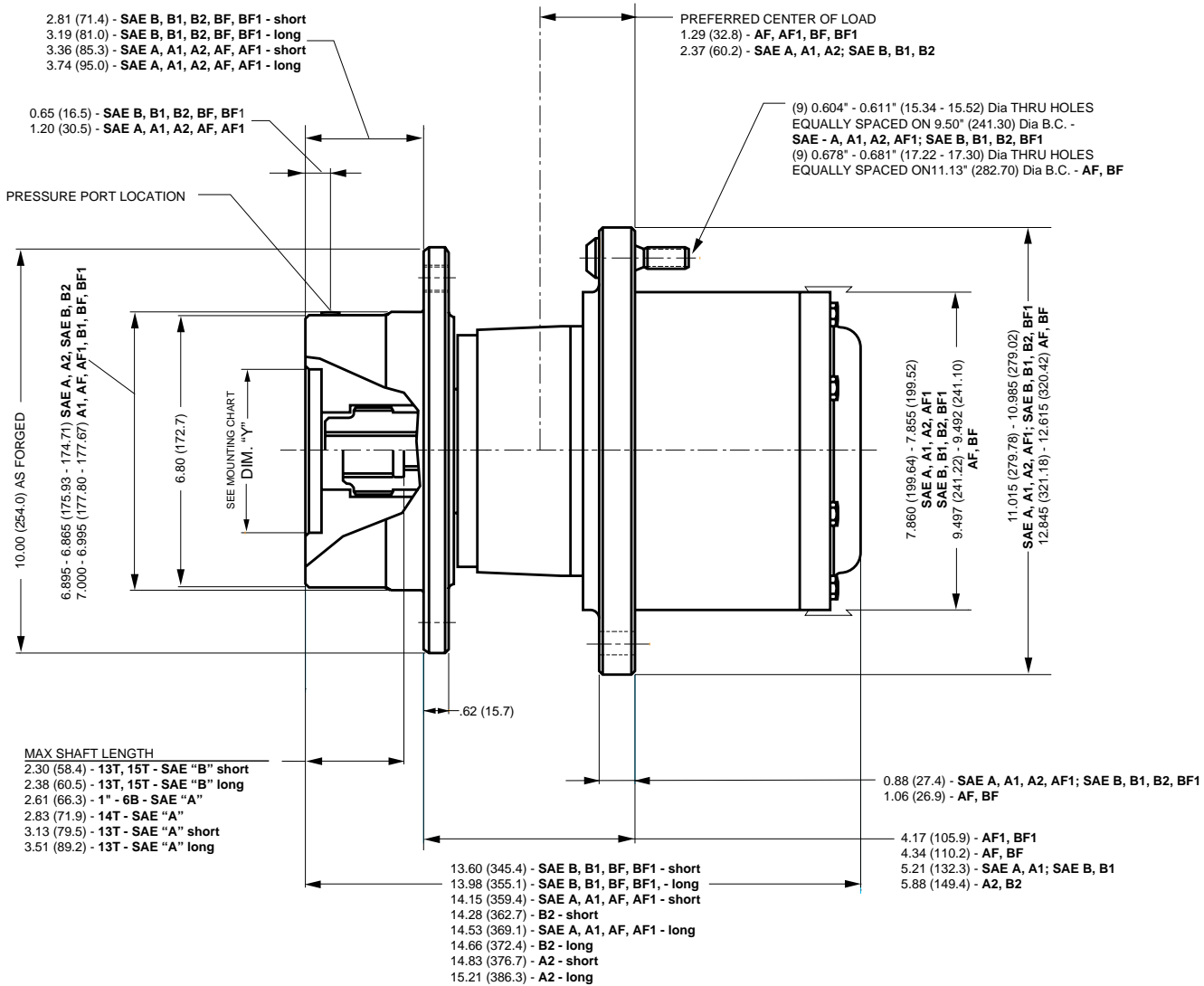

BRAKE RATINGS

MODEL	TORQUE	MINIMUM RELEASE PRESSURE	STYLE
B1	1,540 lb-in (174 N-m)	190 PSI (13.1 Bar)	Short
B2	1,800 lb-in (203 N-m)	220 PSI (15.1 Bar)	Short
B3	2,400 lb-in (271 N-m)	290 PSI (20.0 Bar)	Short
B4	2,400 lb-in (271 N-m)	160 PSI (11.0 Bar)	Long
B5	3,200 lb-in (362 N-m)	220 PSI (15.1 Bar)	Long
B6	3,600 lb-in (407 N-m)	230 PSI (15.8 Bar)	Long
B7	4,200 lb-in (475 N-m)	260 PSI (17.9 Bar)	Long

Maximum Release Pressure = 3,000 PSI (206.4 Bar)

FEATURE CHART: MODEL 7 WHEEL DRIVES DOUBLE REDUCTION with BRAKE

OPTIONS	DESCRIPTION	MAKE ALL SELECTIONS WITHIN ONE COLUMN			ORDER CODES	USE OPTION ORDER CODES TO BUILD ORDER NUMBER			
MOTOR PILOT/HUB	SAEA A1 A2 AF AF1	•	•		7WA 7WA1 7WA2 7WAF 7WAF1				
	SAE B B1 B2 BF BF1	•	•	•	7WB 7WB1 7WB2 7WBF 7WBF1	7WB			
INPUT SPLINE	13T. - 16/32" 14T. - 12/24" 15T. - 16/32" 1" - 6B	•		•	13 14 15 6B		15		
RATIO OPTIONS	13.06:1 15.88:1 17.94:1 19.62:1 21.74:1 24.53:1 28.37:1 32.79:1	•	•	•	13 15 17 19 21 24 28 32		19		
WHEEL STUDS	1/2" by 2.50 9/16" by 2.75 5/8" by 2.37 NONE	•	•	•	5 7 8 0		7		
PARKING BRAKE	SHORT VERSION 1,540 lb-in 1,800 lb-in 2,400 lb-in	•	•	•	B1 B2 B3				
	LONG VERSION 2,400 lb-in 3,200 lb-in 3,600 lb-in 4,200 lb-in	•	•	•	B4 B5 B6 B7		B4		
SPECIAL FEATURES	Boot Seal Quick Disconnect Oil Plugs/Spindle Side	•	•	•	Z Q P				Z
Select desired characteristics from chart, note correct order codes, and order using sample format shown at right:					7WB 15 19 7 B4 Z				

BOLDFACE INDICATES REGULAR VOLUME PRODUCED ITEMS WITH BEST AVAILABILITY.

MOTOR MOUNTING CHART

DIMENSION "X"	DIM. "Y"
SAE A, A1, A2, AF, AF1 (2) - .375 (12.70) -16 UNC,- 2B Thd Holes Equally Spaced on 4.188 (106.38) B. C.*	Ø 3.251 - 3.256 (82.58 - 82.70)
AND (4) - .500 (12.70) -13 UNC,- 2B Thd Holes on 4.188 (106.38) B. C.*	
SAE B, B1, B2, BF, BF1 (2) - .500 (12.70) -13 UNC. 2B Thd Holes Equally Spaced on 5.750 (146.05) B. C.*	Ø 4.001 - 4.006 (101.62 - 101.75)

*"O" RING OR GASKET REQUIRED (Not Supplied by Auburn Gear)
"O" RING SIZES: SAE "A" 2-042, SAE "B" 2-155

NOTE:

The data presented in this catalog is for general information and preliminary layout purposes only. Auburn Gear, through its policy of continual improvement, reserves the right to update its products; therefore, the information presented is subject to change. For specific application and/or dimensional information, contact Auburn Gear.

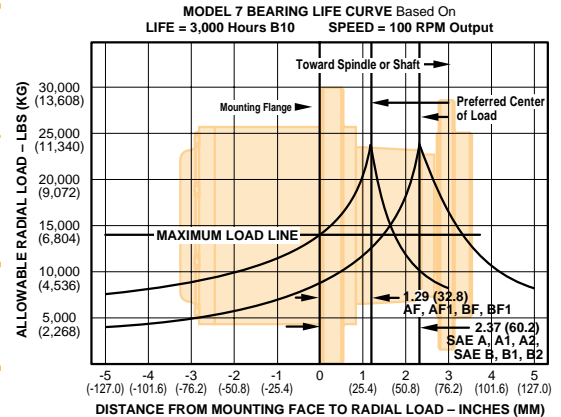

NOTE:

These curves are supplied as a design guide and apply to resultant radial load only. They indicate the importance of maintaining wheel position over the bearing center.

For actual analysis, applications should be reviewed by Auburn Gear Engineering using data supplied on Application Data Form.

BEARING LOAD, LIFE AND SPEED RELATIONSHIPS

$$LF = \frac{SF \times R}{R'}$$

R = Allowable resultant load for given location from mounting flange

R' = Anticipated load at location from mounting flange

LF = Life Factor from table (see below)

SF = Speed Factor from table (see below)

OUTPUT SPEED (RPM)	SF	LF	BEARING HOURS B-10 LIFE
5	2.456	.584	500
10	1.994	.719	1000
20	1.620	.812	1500
30	1.435	.886	2000
40	1.316	.947	2500
50	1.231	1.000	3000
60	1.165	1.047	3500
70	1.113	1.090	4000
80	1.069	1.130	4500
90	1.032	1.166	5000
100	1.000	1.231	6000
200	.812	1.289	7000
300	.719	1.342	8000
400	.659	1.390	9000
500	.617	1.435	10000

CAUTION: The same torsional loading constraints used in the driving mode must be used in the braking mode when braking through the **Power Wheel** drive gear set.

Model 7 Shaft Output Drives Double Reduction

GENERAL SPECIFICATIONS

Max. intermittent output torque ¹	70,000 lb-in (7,910 Nm)	Approximate Weight	107 lbs (49 kg)
Max. input speed	5,000 RPM	Oil capacity	31 oz (920 cc)

For Lubrication Data, see Page 15

¹ Depending on the duty cycle and the nature of the application, a normal continuous output torque of 1/3 to 1/2 of the Maximum Intermittent should yield satisfactory *Power Wheel* life. Also, due to the Model 7's unique combination of small physical size and high torque potential, thermal capacity may become a limiting factor. Customer testing and application analysis is strongly recommended.

Dimensions given in: INCHES (mm)

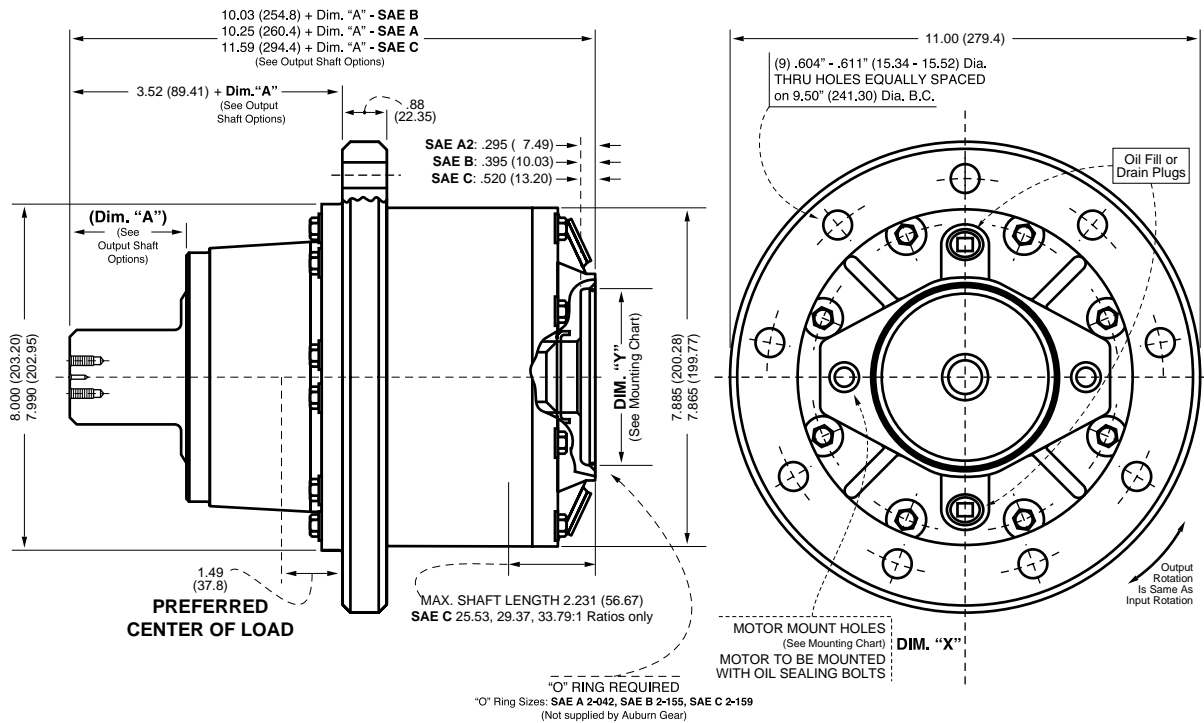

FEATURE CHART: MODEL 7 SHAFT OUTPUT DRIVES DOUBLE REDUCTION

OPTIONS	DESCRIPTION	MAKE ALL SELECTIONS WITHIN ONE COLUMN		ORDER CODES	USE OPTION ORDER CODES TO BUILD ORDER NUMBER		
MOTOR PILOT/HUB	SAE A2 SAE B SAE C	•	•	7SA2 7SB 7SC	7SB		
INPUT SPLINE	13T. 16/32" 14T. 12/24"	•	•	13 14	13		
RATIO OPTIONS	14.06:1 16.88:1 18.94:1 20.62:1 22.74:1 25.53:1 29.37:1 33.79:1	•	•	14 16 18 20 22 25 29 33		22	
OUTPUT SHAFTS	3.0" KEYED 23T - 8/16"	•	•	K2 23			K2
Select desired characteristics from chart, note correct order codes, and order using sample format shown at right:					7SB 13 22 K2		

BOLDFACE INDICATES REGULAR VOLUME PRODUCED ITEMS WITH BEST AVAILABILITY.

MODEL 7 BEARING LIFE CURVE Based On
LIFE = 3,000 Hours B10 SPEED = 100 RPM Output

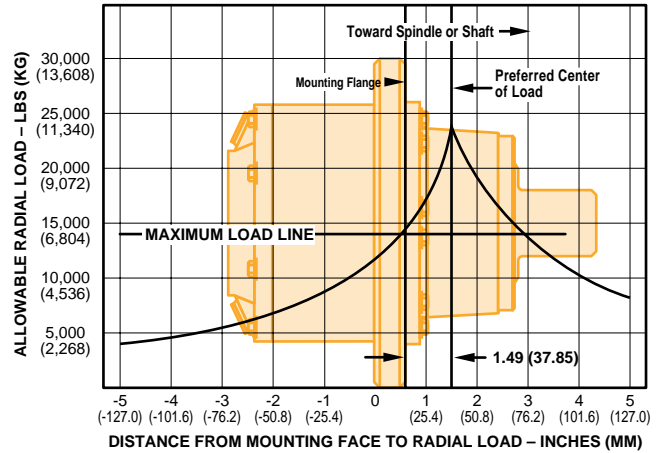

NOTE:

These curves are supplied as a design guide and apply to resultant radial load only. They indicate the importance of maintaining wheel position over the bearing center.

For actual analysis, applications should be reviewed by Auburn Gear Engineering using data supplied on Application Data Form.

MOTOR MOUNTING CHART

DIMENSION "X"	DIM. "Y"
SAE A2 (2) – .500 (12.70) -13 UNC,-2B Thd Holes Equally Spaced on 4.188 (106.38) B. C.*	Ø 3.251 - 3.256 (82.58 - 82.70)
SAE B (2) – .500 (12.70) -13 UNC,-2B Thd Holes Equally Spaced on 5.750 (146.05) B. C.*	Ø 4.001 - 4.006 (101.62 - 101.75)
SAE C (2) – .625 (15.87) -11 UNC,-2B Thd Holes Equally Spaced on 7.125 (180.97) B. C.* <i>OR</i> (4) – .500 (12.70) -13 UNC,-2B Thd Holes Equally Spaced on 6.375 (161.93) B. C.*	Ø 5.001 - 5.006 (127.02 - 127.15)

*"O" RING OR GASKET REQUIRED (Not Supplied by Auburn Gear)
"O" RING SIZES: SAE "A" 2-042, SAE "B" 2-155, SAE "C" 2-159

NOTE:

The data presented in this catalog is for general information and preliminary layout purposes only. Auburn Gear, through its policy of continual improvement, reserves the right to update its products; therefore, the information presented is subject to change. For specific application and/or dimensional information, contact Auburn Gear.

BEARING LOAD, LIFE AND SPEED RELATIONSHIPS

$$LF = \frac{SF \times R}{R'}$$

R = Allowable resultant load for given location from mounting flange

R' = Anticipated load at location from mounting flange

LF = Life Factor from table (*see below*)

SF = Speed Factor from table (*see below*)

OUTPUT SPEED (RPM)	SF	LF	BEARING HOURS B-10 LIFE
5	2.456	.584	500
10	1.994	.719	1000
20	1.620	.812	1500
30	1.435	.886	2000
40	1.316	.947	2500
50	1.231	1.000	3000
60	1.165	1.047	3500
70	1.113	1.090	4000
80	1.069	1.130	4500
90	1.032	1.166	5000
100	1.000	1.231	6000
200	.812	1.289	7000
300	.719	1.342	8000
400	.659	1.390	9000
500	.617	1.435	10000

CAUTION: The same torsional loading constraints used in the driving mode must be used in the braking mode when braking through the **Power Wheel** drive gear set.

Model 7 Shaft Output Drives Double Reduction with A2 Series Integral Parking Brake¹

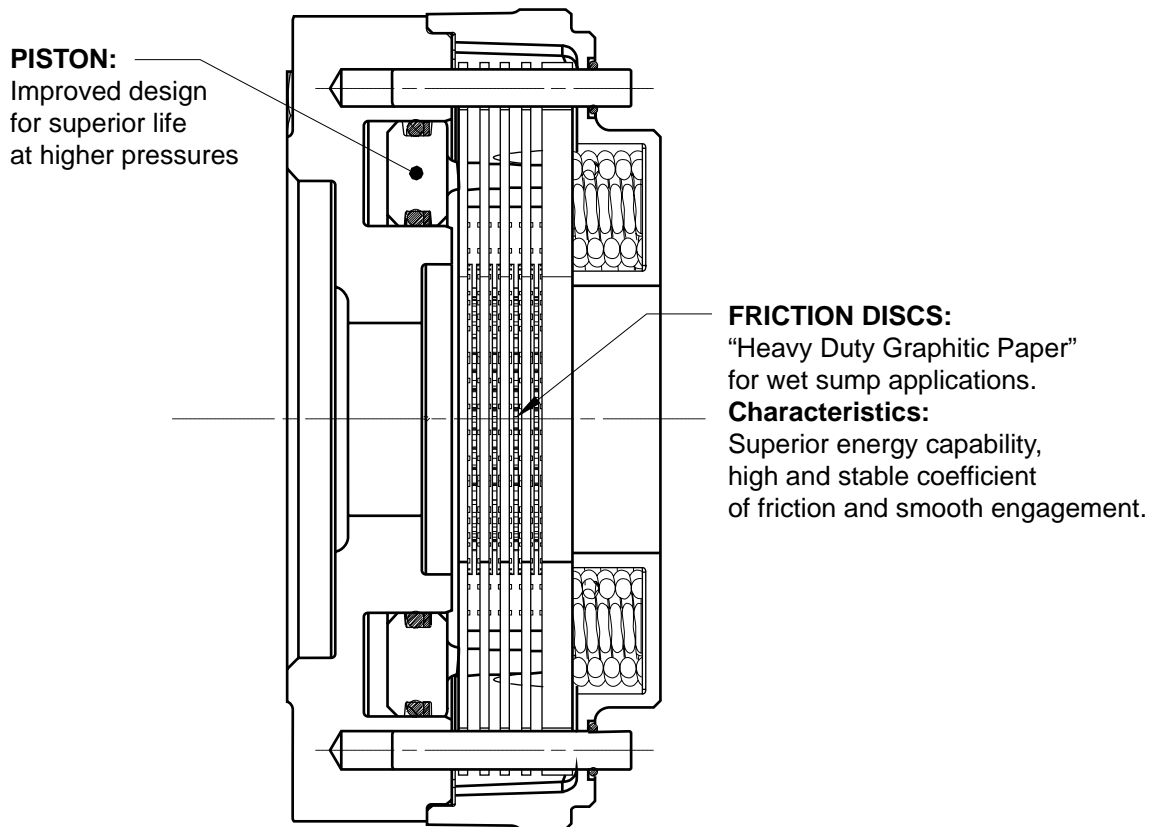

GENERAL A2 SERIES DATA:

1. Maximum operating pressure is 3,000 psi (206.4 Bar). Pressure spikes or surges not to exceed 3,500 psi (240.8 Bar). Surge pressure in excess of 3,500 psi (240.8 Bar) caused by spikes in the hydraulic system could shorten brake life and must be avoided.
2. Use only SAE grade 8 mounting bolts and torque to 80-90 lb. ft. (108-122 N-m) for motor mounting.
3. **PRECAUTION:** Bench testing may cause distortion of components or bolt failure. Mounting bolts must be used for supplemental clamping.
4. Minimum Release Pressure is defined as the hydraulic pressure required to obtain full running clearance.
5. Cubic Inch Displacement is the volume of oil required to release the brake piston 1.0 in³ (16.4cc) for a new brake and 2.0 in³ (32.8cc) for a worn brake pack.
6. For vertical shaft output applications, shaft up or shaft down, please contact Auburn Gear to insure proper brake configuration is specified.

Model 7 Shaft Output Drives Double Reduction with A2 Series Integral Parking Brake¹

GENERAL SPECIFICATIONS

Max. intermittent output torque ²	70,000 lb-in (7,910 Nm)	Approximate Weight	137 lbs (62 kg)
Max. input speed ³	2,000 RPM	Oil capacity	42 oz (1250 cc)

For Lubrication Data, see Page 15

¹For vertical applications, shaft up or shaft down, contact Auburn Gear.

² Depending on the duty cycle and the nature of the application, a normal continuous output torque of 1/3 to 1/2 of the Maximum Intermittent should yield satisfactory *Power Wheel* life. Also, due to the Model 7's unique combination of small physical size and high torque potential, thermal capacity may become a limiting factor.

³ For input speed between 2,000 and 3,600 rpm please contact Auburn Gear for duty cycle analysis.

Customer testing and application analysis is strongly recommended.

Dimensions given in: INCHES (mm)

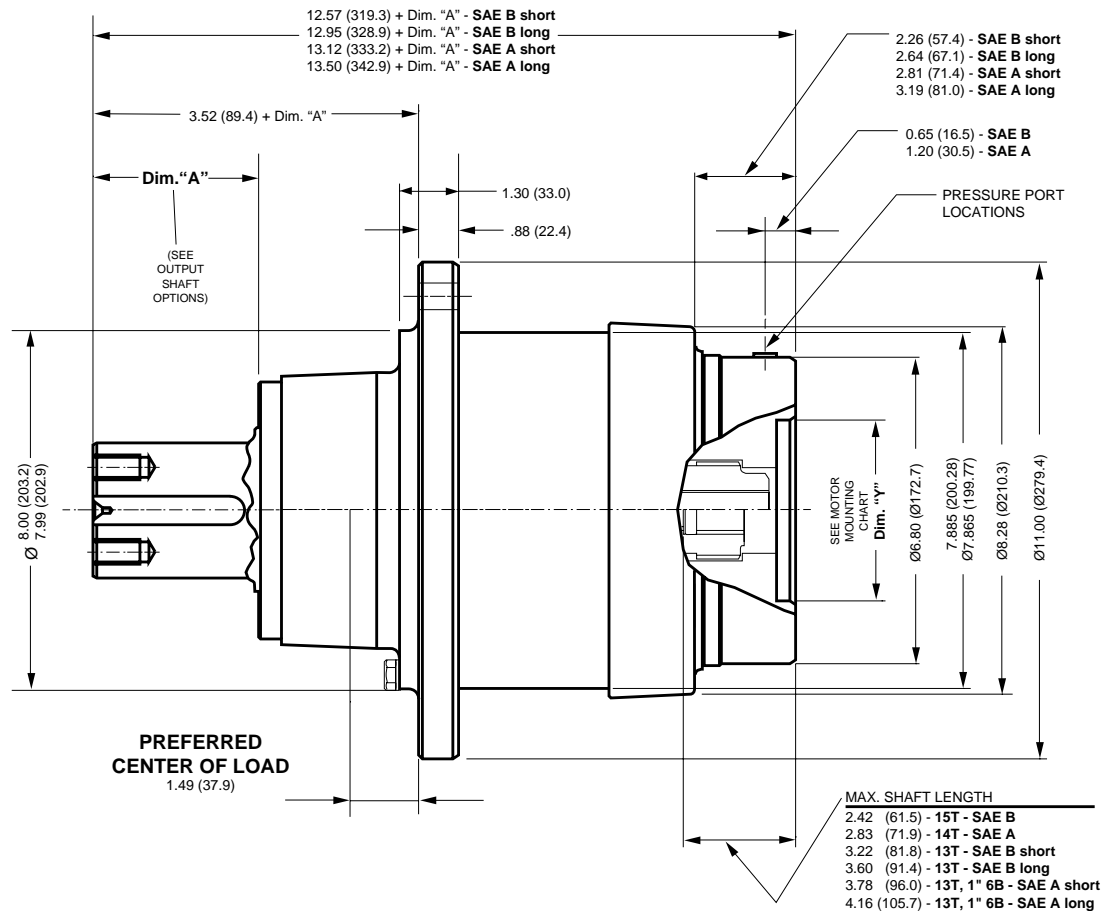

BRAKE RATINGS

MODEL	TORQUE	MINIMUM RELEASE PRESSURE	STYLE
B1	1,540 lb-in (174 N-m)	190 PSI (13.1 Bar)	Short
B2	1,800 lb-in (203 N-m)	220 PSI (15.1 Bar)	Short
B3	2,400 lb-in (271 N-m)	290 PSI (20.0 Bar)	Short
B4	2,400 lb-in (271 N-m)	160 PSI (11.0 Bar)	Long
B5	3,200 lb-in (362 N-m)	220 PSI (15.1 Bar)	Long
B6	3,600 lb-in (407 N-m)	230 PSI (15.8 Bar)	Long
B7	4,200 lb-in (475 N-m)	260 PSI (17.9 Bar)	Long

Maximum Release Pressure = 3,000 PSI (206.4 Bar)

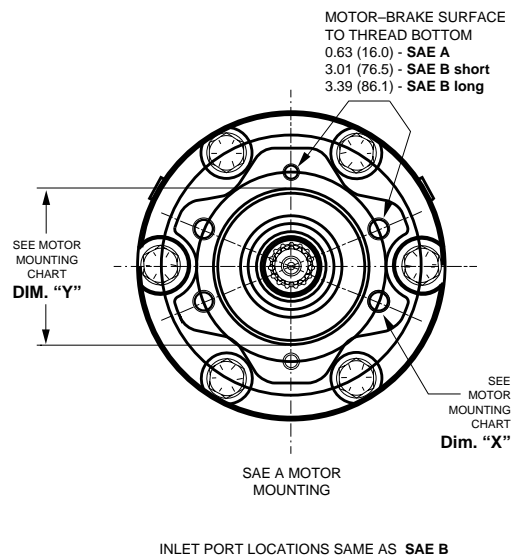
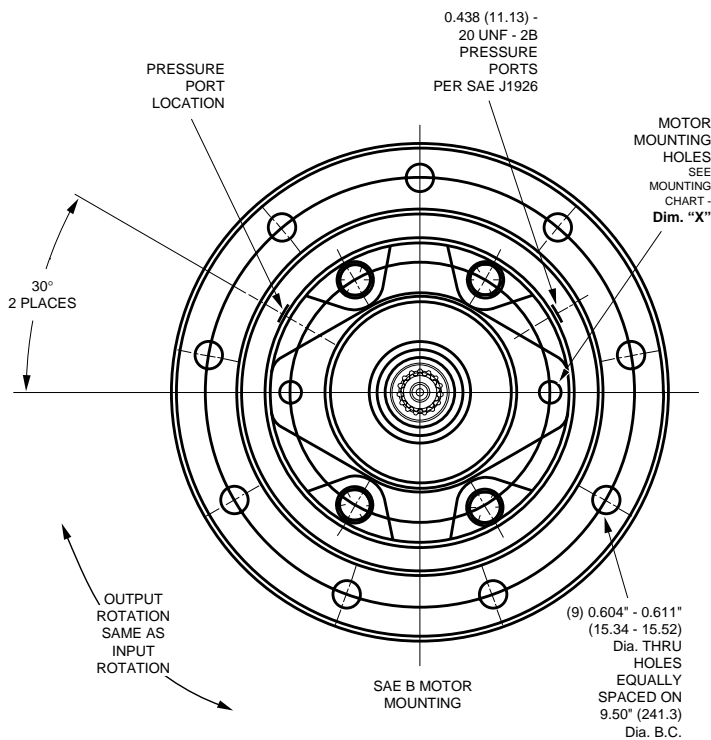

FEATURE CHART: MODEL 7 SHAFT OUTPUT DRIVES DOUBLE REDUCTION with BRAKE

OPTIONS	DESCRIPTION	MAKE ALL SELECTIONS WITHIN ONE COLUMN		ORDER CODES	USE OPTION ORDER CODES TO BUILD ORDER NUMBER	
MOTOR PILOT/HUB	SAE A SAE B	•	•	7SA 7SB		
INPUT SPLINE	13T. - 16/32" 14T. - 12/24" 15T. - 16/32" 1" - 6B	•	•	13 14 15 6B	13	
RATIO OPTIONS	14.06:1 16.88:1 18.94:1 20.62:1 22.74:1 25.53:1 29.37:1 33.79:1	•	•	14 16 18 20 22 25 29 33		20
OUTPUT SHAFTS	3.0" KEYED 23T-9/16	•	•	K2 23L		K2
PARKING BRAKE	SHORT VERSION 1,540 lb-in 1,800 lb-in 2,400 lb-in	•	•	B1 B2 B3		
	LONG VERSION 2,400 lb-in 3,200 lb-in 3,600 lb-in 4,200 lb-in	•	•	B4 B5 B6 B7		B4
Select desired characteristics from chart, note correct order codes, and order using sample format shown at right:					7SB 13 20 K2 B4	

BOLDFACE INDICATES REGULAR VOLUME PRODUCED ITEMS WITH BEST AVAILABILITY.

▲ For vertical applications, shaft up or shaft down, contact Auburn Gear.

MOTOR MOUNTING CHART

DIMENSION "X"	DIM. "Y"
SAE A (2) – .375 (12.70) -16 UNC, -2B Thd Holes Equally Spaced on 4.188 (106.38) B. C. ▲ AND (4) – .500 (12.70) -13 UNC, -2B Thd Holes on 4.188 (106.38) B. C. ▲	Ø 3.251 - 3.256 (82.58 - 82.70)
SAE B (2) – .500 (12.70) -13 UNC. 2B Thd Holes Equally Spaced on 5.750 (146.05) B. C. ▲	Ø 4.001 - 4.006 (101.62 - 101.75)

▲ "O" RING OR GASKET REQUIRED (Not Supplied by Auburn Gear)
"O" RING SIZES: SAE "A" 2-042, SAE "B" 2-155

NOTE:

The data presented in this catalog is for general information and preliminary layout purposes only. Auburn Gear, through its policy of continual improvement, reserves the right to update its products; therefore, the information presented is subject to change. For specific application and/or dimensional information, contact Auburn Gear.

MODEL 7 BEARING LIFE CURVE Based On
LIFE = 3,000 Hours B10 SPEED = 100 RPM Output

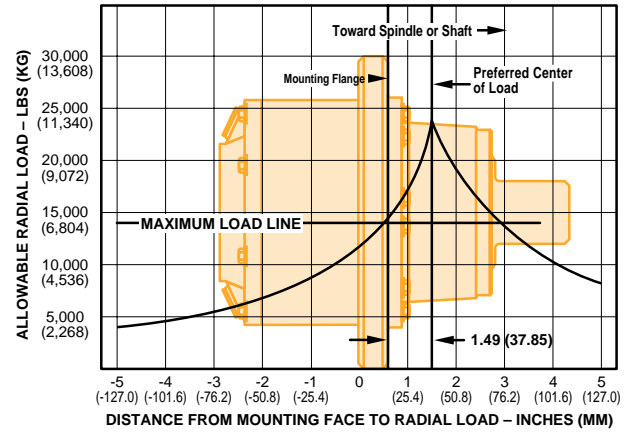

NOTE:

These curves are supplied as a design guide and apply to resultant radial load only. They indicate the importance of maintaining wheel position over the bearing center.

For actual analysis, applications should be reviewed by Auburn Gear Engineering using data supplied on Application Data Form.

BEARING LOAD, LIFE AND SPEED RELATIONSHIPS

$$LF = \frac{SF \times R}{R'}$$

R = Allowable resultant load for given location from mounting flange

R' = Anticipated load at location from mounting flange

LF = Life Factor from table (see below)

SF = Speed Factor from table (see below)

OUTPUT SPEED (RPM)	SF	LF	BEARING HOURS B-10 LIFE
5	2.456	.584	500
10	1.994	.719	1000
20	1.620	.812	1500
30	1.435	.886	2000
40	1.316	.947	2500
50	1.231	1.000	3000
60	1.165	1.047	3500
70	1.113	1.090	4000
80	1.069	1.130	4500
90	1.032	1.166	5000
100	1.000	1.231	6000
200	.812	1.289	7000
300	.719	1.342	8000
400	.659	1.390	9000
500	.617	1.435	10000

CAUTION: The same torsional loading constraints used in the driving mode must be used in the braking mode when braking through the **Power Wheel** drive gear set.

Model 7 Shaft Input/Shaft Output Drives - Double Reduction

GENERAL SPECIFICATIONS

Max. intermittent output torque¹ 70,000 lb-in (7,910 Nm) Approximate Weight 122 lbs (55 kg)
 Max. input speed 5,000 RPM Oil capacity 42 oz (1250 cc)

For Lubrication Data, see Page 15

¹ Depending on the duty cycle and the nature of the application, a normal continuous output torque of 1/3 to 1/2 of the Maximum Intermittent should yield satisfactory *Power Wheel* life. Also, due to the Model 7's unique combination of small physical size and high torque potential, thermal capacity may become a limiting factor. Customer testing and application analysis is strongly recommended.

Dimensions given in: INCHES (mm)

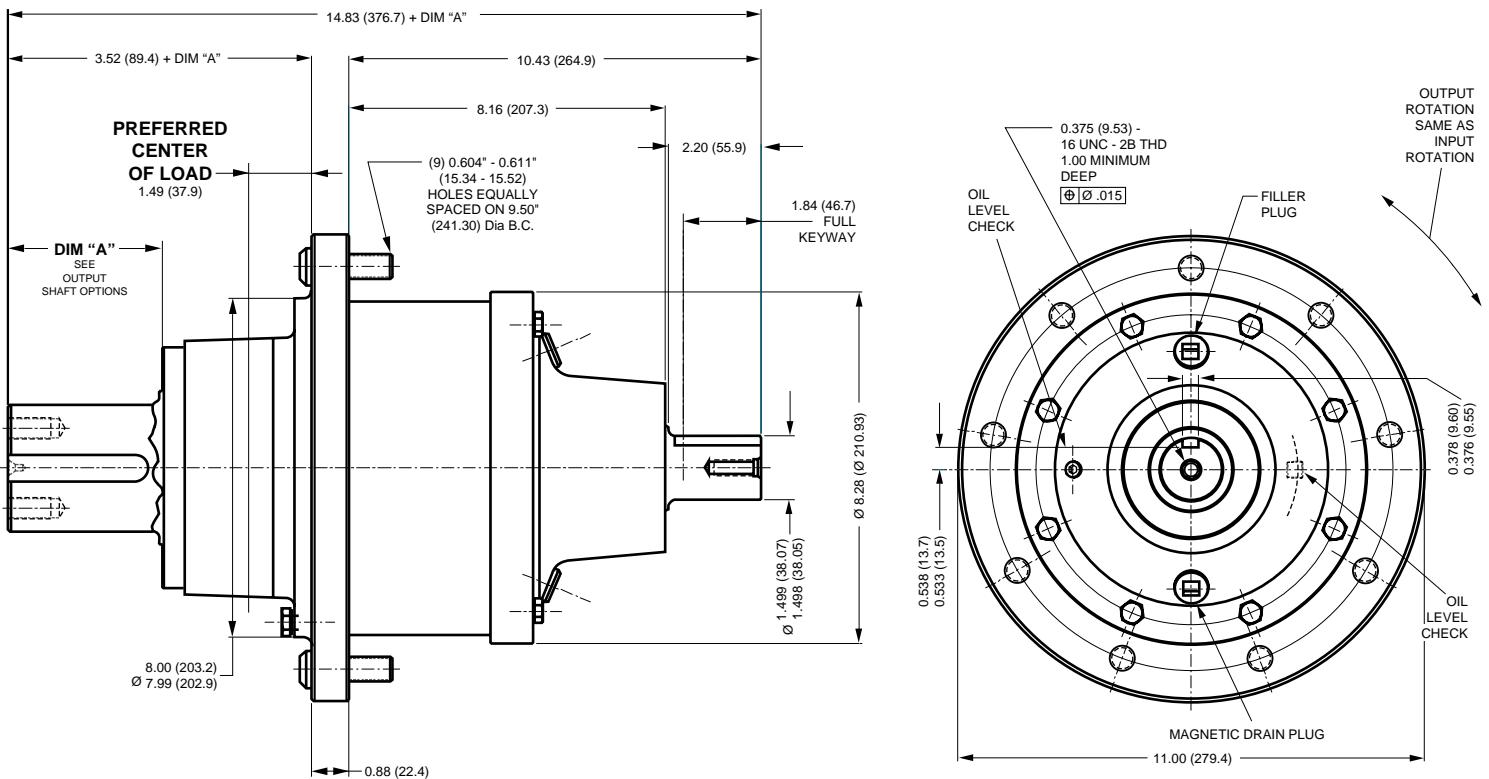

FEATURE CHART: MODEL 7 SHAFT INPUT/SHAFT OUTPUT DRIVES - DOUBLE REDUCTION

OPTIONS	DESCRIPTION	MAKE ALL SELECTIONS WITHIN ONE COLUMN	ORDER CODES	USE OPTION ORDER CODES TO BUILD ORDER NUMBER	
HUB	STD Model 7 Shaft Output Double Red.	•	7S	7S	
INPUT SHAFT OPTIONS	1 1/2" Keyed	•	K00	K00	
RATIO OPTIONS	14.06:1 16.88:1 18.94:1 20.62:1 22.74:1 25.53:1 29.73:1 33.79:1	• • • • • • •	14 16 18 20 22 25 29 32		20
OUTPUT SHAFTS	3.00" Keyed 23T - 8/16"	•	K2 23		23
Select desired characteristics from chart, note correct order codes, and order using sample format shown at right:				7S K00 20 23	

BOLDFACE INDICATES REGULAR VOLUME PRODUCED ITEMS WITH BEST AVAILABILITY.

MODEL 7 BEARING LIFE CURVE Based On
LIFE = 3,000 Hours B10 SPEED = 100 RPM Output

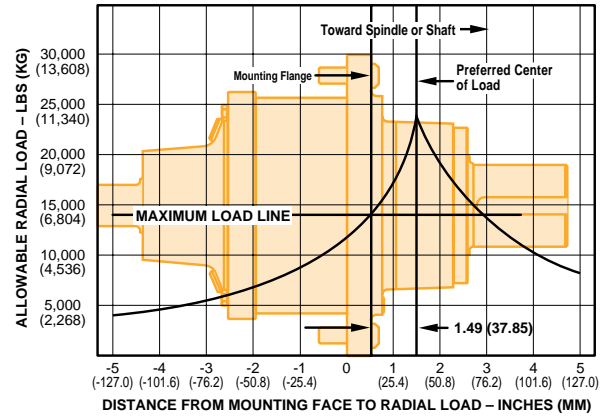

NOTE:

These curves are supplied as a design guide and apply to resultant radial load only. They indicate the importance of maintaining wheel position over the bearing center.

For actual analysis, applications should be reviewed by Auburn Gear Engineering using data supplied on Application Data Form.

BEARING LOAD, LIFE AND SPEED RELATIONSHIPS

$$LF = \frac{SF \times R}{R'}$$

R = Allowable resultant load for given location from mounting flange

R' = Anticipated load at location from mounting flange

LF = Life Factor from table (*see below*)

SF = Speed Factor from table (*see below*)

OUTPUT SPEED (RPM)	SF	LF	BEARING HOURS B-10 LIFE
5	2.456	.584	500
10	1.994	.719	1000
20	1.620	.812	1500
30	1.435	.886	2000
40	1.316	.947	2500
50	1.231	1.000	3000
60	1.165	1.047	3500
70	1.113	1.090	4000
80	1.069	1.130	4500
90	1.032	1.166	5000
100	1.000	1.231	6000
200	.812	1.289	7000
300	.719	1.342	8000
400	.659	1.390	9000
500	.617	1.435	10000

CAUTION: The same torsional loading constraints used in the driving mode must be used in the braking mode when braking through the **Power Wheel** drive gear set.

NOTE:

The data presented in this catalog is for general information and preliminary layout purposes only. Auburn Gear, through its policy of continual improvement, reserves the right to update its products; therefore, the information presented is subject to change. For specific application and/or dimensional information, contact Auburn Gear.

Output Shaft Options

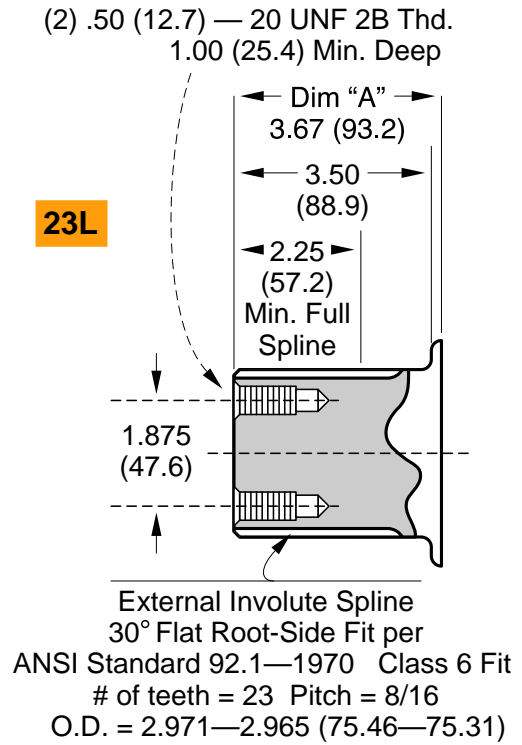
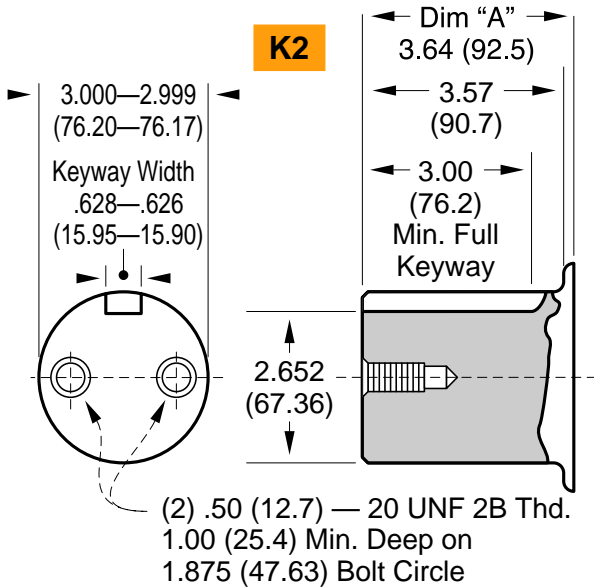

Other Options

Boot Seal

An optional seal that protects the main oil seal from dirt and other debris. The boot seal will give extended life on applications operating in extremely muddy or dirty conditions. Boot seals are available on a selective model basis.

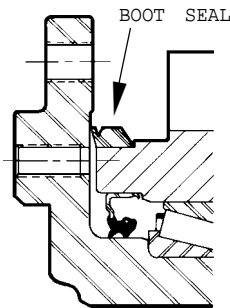

Weldable Hub

The hubs are 4140H steel and can be turned down and/or welded for mounting sprockets, pulleys, or other devices. A circular keeper plate secures the hub to the splined output shaft with two bolts (keeper plate and bolts included).

KIT NUMBER	SPLINE	FITS MODELS
6420105	23T- ¹² / ₂₄	5, 6, & 8
6420106	23T- ⁸ / ₁₆	7, 8, 9, & 10
6420107	20T- ⁸ / ₁₆	8, & 9

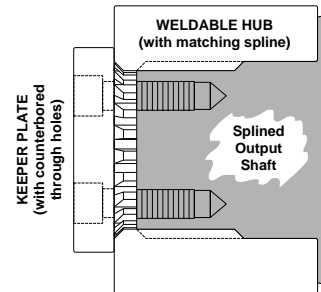

Quick Disconnect

This optional disconnect is available on all wheel drives. No tools are needed to disengage or re-engage the drive. The planetary drive is disengaged with the push of a button. The quick disconnect eliminates removal of the disconnect cover and external contaminants are sealed from the units by internal o-rings and a gasket that is sandwiched between the disconnect and planetary cover. The rugged, compact design ensures dependable service.

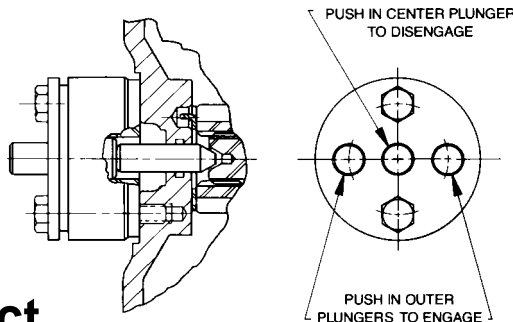

Lubrication Data

Power Wheel Planetary Drives are shipped without lubricant and must be filled to the proper level prior to start-up.

1. Type

In normal applications use an extreme pressure lubricant API-GL-5 approved. AGI recommends SAE 80W, 90, 80W-90 and 85W-90 grades of lube under normal climate and operating conditions. See chart below. For severe or abnormal applications with special requirements consult either Auburn Gear or a lubricant manufacturer for further assistance.

2. Change Interval

Initial lubrication change after 50 hours of operation. Subsequent changes every 1000 hours or yearly whichever comes first.

3. Lube Temperature

Continuous operating temperatures of 160°F are allowable. Maximum intermittent temperature recommended is 200°F.

4. Amount of Lube

The unit should be half full when mounted horizontal. Lube levels for other mounts will vary. Consult Auburn Gear for details.

5. Shaft or Spindle Up Mounting

If mounting unit vertically with shaft or spindle up, special provisions apply to ensure adequate lubrication of output bearings. Consult Auburn Gear.

Auburn Gear Power Wheel Low Temperature Gear Lube Requirement	
SAE Viscosity Grade	Auburn Gear Recommended Minimum Temperature
75W-90	-40°F (-40°C)*
80W, 80W-90	-15°F (-26°C)*
85W, 85W-90	10°F (-12°C)*
90	35°F (2°C)

* Maximum temperature for Brookfield Viscosity¹ of 150,000 centipoise (cP)² per SAE J306 MAR85

¹ Brookfield Viscosity - *apparent viscosity* as determined under ASTM D 2983

² 150,000 cP determined to provide sufficient low temperature lube properties for Auburn Gear Power Wheels

Warranty Information

Power Wheel® Warranty

Seller warrants to Purchaser that its Power Wheel® planetary gear products are free from defects in material and workmanship under normal use and service for a period of one year from the date the product is shown to have been placed into operation by original user or for two years from date of shipment from seller's plant, whichever shall first occur.

Seller's obligation under this warranty is expressly limited to the repair or replacement at its option, of the Power Wheel which is returned with a written claim of defect f.o.b. seller's factory, Auburn, Indiana, U.S.A., and which is determined by Seller to be defective in fact.

THIS IS THE SOLE AND ONLY WARRANTY OF SELLER AND NO OTHER WARRANTY IS APPLICABLE, EITHER EXPRESSED OR IMPLIED, IN FACT OR BY LAW, INCLUDING ANY WARRANTY AS TO MERCHANTABILITY OR FITNESS FOR A PARTICULAR USE OR PURPOSE.

The sole and only remedy in regard to any defective Power Wheel shall be the repair or replacement thereof herein provided, and seller shall not be liable for any consequential, special, incidental, or punitive damages, losses or expenses resulting from or caused by any defects.

AUBURN GEAR, INC.

AUBURN, INDIANA, U.S.A.





400 East Auburn Drive
Auburn, Indiana 46706-3499 • USA
PH: (219) 925-3200
FAX: (219) 925-4725
E-mail: auburngear@mail.fwi.com
Web: <http://www.auburngear.com>



*All specifications and data contained herein are nominal and subject to change without notice.
Specific applications should be referred to Auburn Gear for current information.*