

Power Wheel®
Model 8 Planetary Gear Drives



MODEL 8

Features & A2 Integral Brake Information.....3

MODEL 8 WHEEL DRIVES

Double Reduction.....4

with A2 Series Integral Parking Brake.....6

MODEL 8 SHAFT & FLANGED OUTPUT DRIVES

Single & Double Reduction.....8

with A2 Series Integral Parking Brake.....10

MODEL 8 FLANGELESS HUB SHAFT & FLANGE OUTPUT DRIVES

Single & Double Reduction.....12

MODEL 8 SHAFT INPUT/OUTPUT DRIVES

Input/Output Drives—Double Reduction.....14

MODEL 8 OPTIONS

Model 8 Shaft & Flanged Output Options.....16

OTHER OPTIONS.....18

INFORMATION

Lubrication Data.....18

Warranty.....19

Power Wheel® Model 8 Features

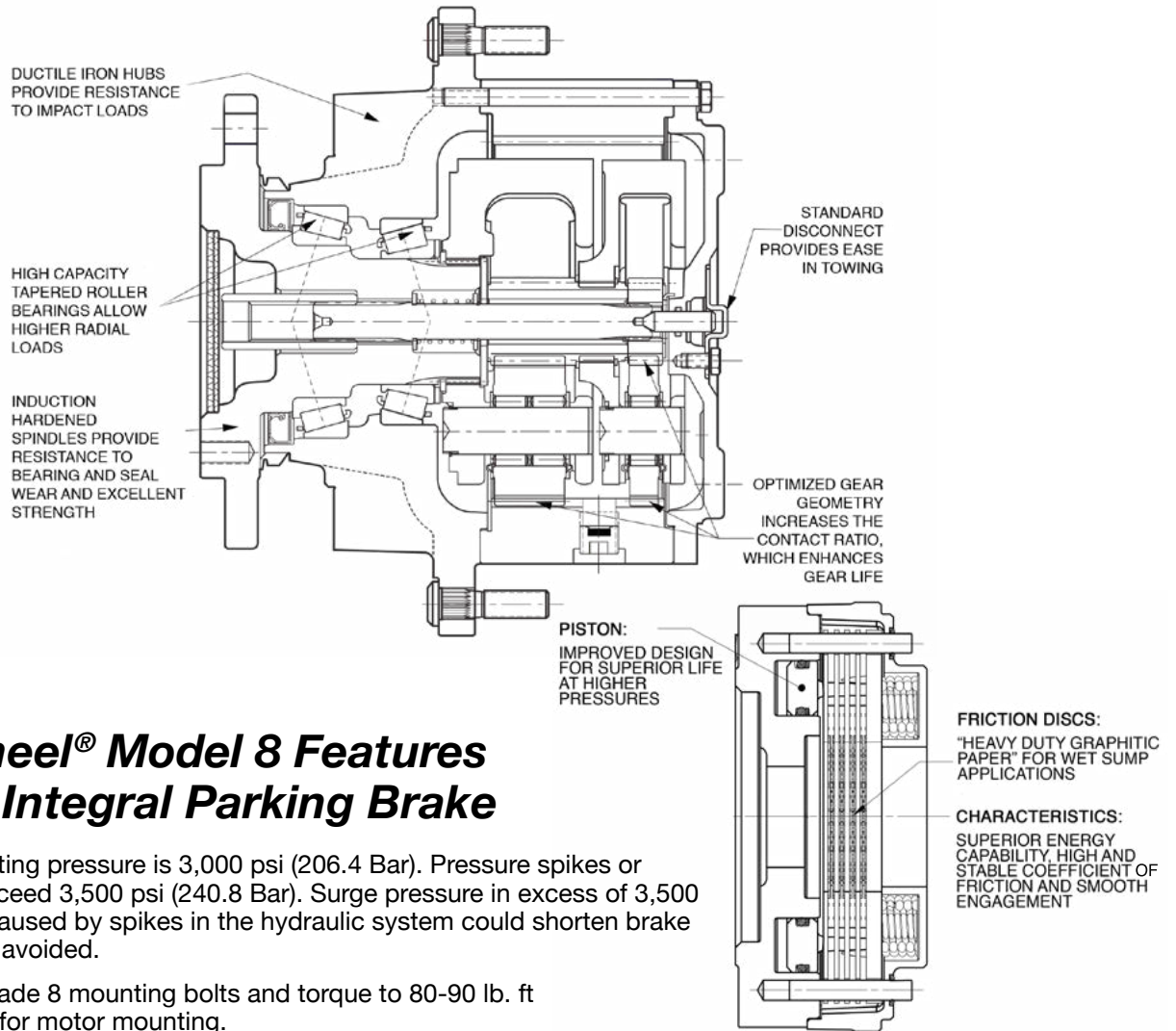

Power Wheel® Model 8 Features A2 Series Integral Parking Brake

1. Maximum operating pressure is 3,000 psi (206.4 Bar). Pressure spikes or surges not to exceed 3,500 psi (240.8 Bar). Surge pressure in excess of 3,500 psi (240.8 Bar) caused by spikes in the hydraulic system could shorten brake life and must be avoided.
2. Use only SAE grade 8 mounting bolts and torque to 80-90 lb. ft (108 - 122 N-m) for motor mounting.
3. **PRECAUTION:** Bench testing may cause distortion of components or bolt failure. Mounting bolts must be used or supplemental clamping.
4. Minimum Release Pressure is defined as the hydraulic pressure required to obtain full running clearance.
5. Cubic Inch Displacement is the volume of oil required to release the brake piston.
 - 1.0 in³ (16.4cc) for a new brake and 2.0 in³ (32.8cc) for a worn brake pack—**SAE A, B**
 - 0.7 in³ (11.5cc) for a new brake and 1.6 in³ (26.2cc) for a worn brake pack—**SAE C**

BRAKE RATINGS

MOUNT	MODEL	TORQUE	MIN. RELEASE PRESSURE	STYLE
SAE A, B	B2	1,800 lb-in (203 N-m)	220 PSI (15.1 Bar)	Short
SAE A, B	B3	2,400 lb-in (271 N-m)	290 PSI (20.0 Bar)	Short
SAE B	B4	2,400 lb-in (271 N-m)	160 PSI (11.0 Bar)	Long
SAE A, B	B5	3,200 lb-in (362 N-m)	220 PSI (15.1 Bar)	Long
SAE B	B6	3,600 lb-in (407 N-m)	230 PSI (15.8 Bar)	Long
SAE A, B	B7	4,200 lb-in (475 N-m)	260 PSI (17.9 Bar)	Long
SAE C	B4	2,400 lb-in (271 N-m)	135 PSI (09.3 Bar)	—
SAE C	B6	3,600 lb-in (407 N-m)	185 PSI (12.4 Bar)	—
SAE C	B7	4,200 lb-in (475 N-m)	210 PSI (14.5 Bar)	—

NOTE:

The data presented in this catalog is for general information and preliminary layout purposes only. Auburn Gear, through its policy of continual improvement, reserves the right to update its products; therefore, the information presented is subject to change. For specific application and/or dimensional information, contact Auburn Gear.

Model 8 Wheel Drives • Double Reduction

GENERAL SPECIFICATIONS

Max. intermittent output torque^{1,2}.....100,000 lb-in (11,300Nm)

Approximate Weight.....169 lbs (76.7 kg)

Max. input speed².....5,000 RPM

Oil Capacity.....47 oz (1,390 cc)

For Lubrication Data, See Pages 18-19

¹ Depending on the duty cycle and the nature of the application, a normal continuous output torque of 1/3 to 1/2 of the maximum intermittent should yield satisfactory Power Wheel life. Customer testing and application analysis is strongly recommended.

² If application exceeds published limits, contact Auburn Gear.

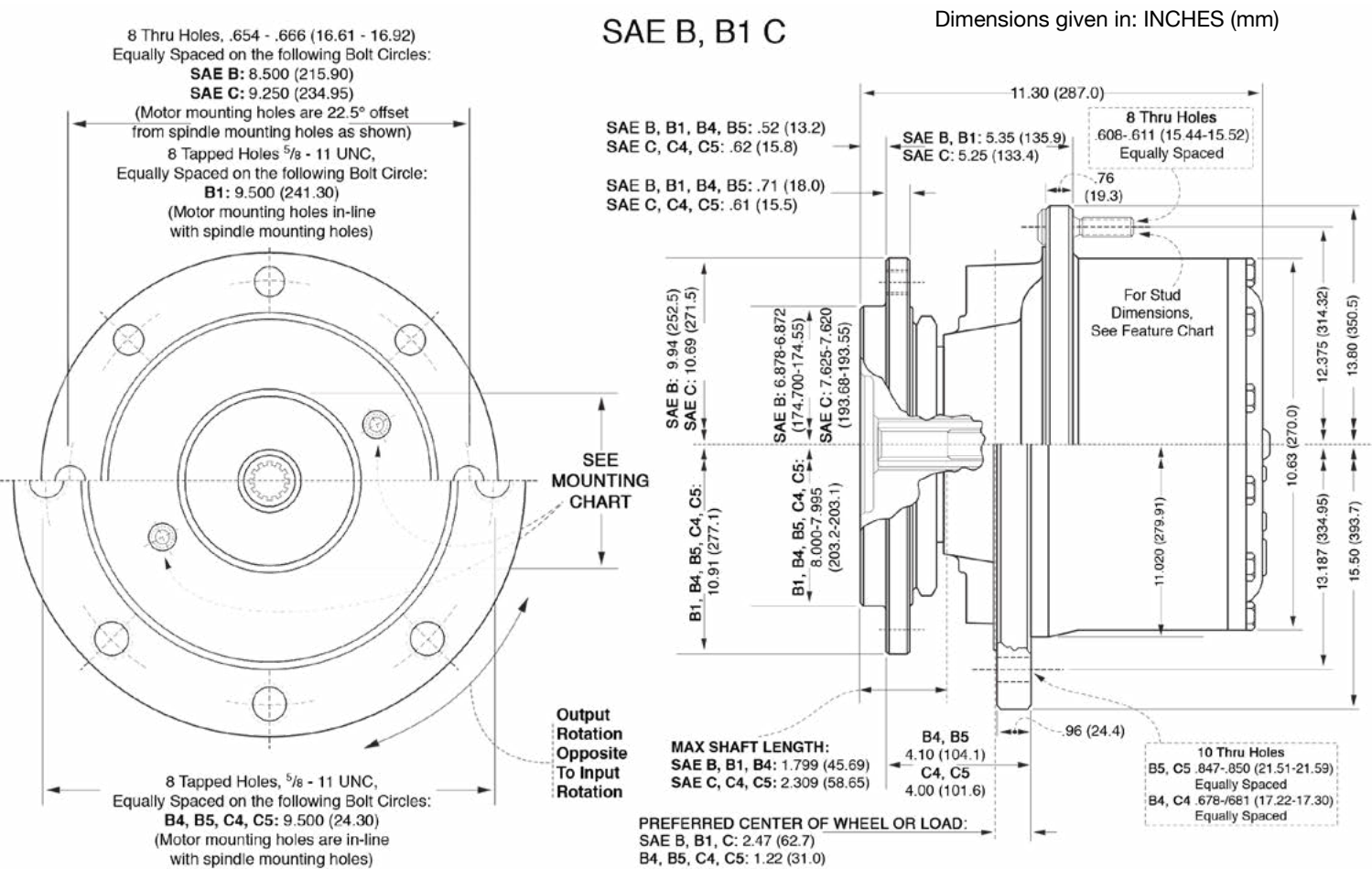

SAE B4, B5, C4, C5

NON-POWERED UNITS ARE ALSO AVAILABLE

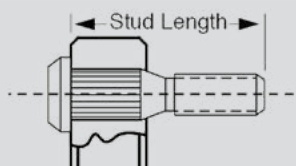

Wheel Stud—Detail

Note that the stud lengths shown in the feature chart represent the total length of the stud under the head.

FEATURE CHART: Model 8 Wheel Drives Double Reduction

OPTIONS	DESCRIPTION	MAKE ALL SELECTIONS WITHIN ONE COLUMN		ORDER CODES	USE OPTION ORDER CODES TO BUILD ORDER NUMBER			
MOTOR PILOT/HUB	SAE B	•		8WB	8WB1			
	B1	•		8WB1				
	B4	•		8WB4				
	B5	•		8WB5				
	SAE C		•	8WC				
	C4		•	8WC4				
C5		•	8WC5					
INPUT SPLINE	13T - ¹⁶ / ₃₂	•		13		13		
	14T - ¹² / ₂₄	•	•	14				
	15T - ¹⁶ / ₃₂	•		15				
RATIO OPTIONS	14.39:1	•	•	14				
	17.83:1	•	•	17				
	22.59:1	•	•	22				
	25.71:1	•	•	25				
	30.50:1	•	•	30				
	34.20:1	•	•	34		34		
	41.42:1	•	•	41				
49.00:1	•	•	49					
WHEEL STUDS	¹ / ₂ " x 2.50	•	•	5				
	⁹ / ₁₆ " x 2.75	•	•	7				
	⁵ / ₈ " x 2.37	•	•	8				8
	³ / ₄ " x 2.76*	•	•	9				
	³ / ₄ " x 3.21*	•	•	11				
	NONE	•	•	0				
SPECIAL FEATURES	Brake Disc**	•	•	D				
	Boot Seal	•	•	Z				
	Brake Disc Holes	•	•	DH				
	Quick Disconnect	•	•	Q				Q
	Oil Plugs/Spindle Side	•	•	P				
	High Strength Carrier	•	•	Y				
	Cartridge Seal	•	•	T				

Select desired characteristics from chart, note correct order codes, and order using sample format shown at right:

8WB1 13 34 8 Q

* Available with B5 and C5 mounting only

** Customer supplied, Auburn Gear assembled

MOTOR MOUNTING CHART

MOTOR MOUNTING HOLE DIMENSIONS	DIAMETER
SAE B, B4, B5: (2) - ¹ / ₂ " -13 UNC 2B Thd Holes on 5.750 (146.05) B. C.	Ø 4.001 - 4.006 (101.62 - 101.75)
SAE C, C4, C5: (4) - ¹ / ₂ " -13 UNC 2B Thd Holes on 6.375 (161.93) B. C.	Ø 5.001 - 5.006 (127.02 - 127.15)

* "O" RING OR GASKET REQUIRED (Not Supplied by Auburn Gear)
"O" RING SIZES: SAE "B" 2-155 (614120), SAE "C" 2-159 (614136)

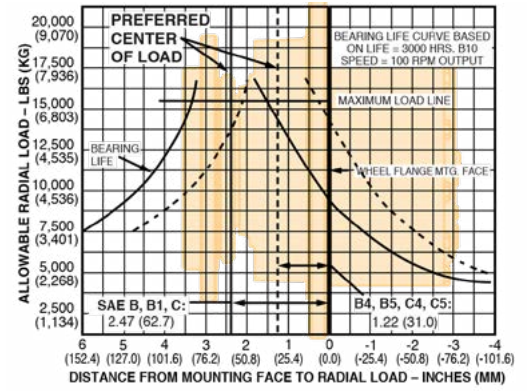

NOTE:

These curves are supplied as a design guide and apply to resultant radial load only. They indicate the importance of maintaining wheel position over the bearing center. For actual analysis, applications should be reviewed by Auburn Gear Engineering using data supplied on Application Data Form.

Bearing Load, Life, and Speed Relationships

$$LF = \frac{SF \times R}{R'}$$

R = Allowable resultant load or given location from mounting flange
R' = Anticipated load at location from mounting flange
LF = Life Factor from table (see Below)
SF = Speed Factor from Table (see Below)

OUTPUT SPEED (RPM)	SF	LF	BEARING HOURS B-10 LIFE
5	2.456	0.584	500
10	1.994	0.719	1000
20	1.620	0.812	1500
30	1.435	0.886	2000
40	1.316	0.947	2500
50	1.231	1.000	3000
60	1.165	1.047	3500
70	1.113	1.090	4000
80	1.069	1.130	4500
90	1.032	1.166	5000
100	1.000	1.231	6000
200	0.812	1.289	7000
300	0.719	1.342	8000
400	0.659	1.390	9000
500	0.617	1.435	10000

CAUTION: The same torsional loading constraints used in the driving mode must be used in the braking mode when braking through the Power Wheel drive gear set.

NOTE:

The data presented in this catalog is for general information and preliminary layout purposes only. Auburn Gear, through its policy of continual improvement, reserves the right to update its products; therefore, the information presented is subject to change. For specific application and/or dimensional information, contact Auburn Gear.

Model 8 Wheel Drives • Double Reduction with A2 Series Integral Parking Brake

GENERAL SPECIFICATIONS

Max. intermittent output torque^{1,2}.....100,000 lb-in (11,300 Nm)
Max. input speed³.....3,500 RPM

Approximate Weight.....186 lbs (84.4 kg)
Oil Capacity.....52 oz (1,540 cc)

¹ Depending on the duty cycle and the nature of the application, a normal continuous output torque of 1/3 to 1/2 of the maximum intermittent should yield satisfactory Power Wheel life. Customer testing and application analysis is strongly recommended.

² If application exceeds published limits, contact Auburn Gear.

³ For input speeds above 3,500 RPM please contact Auburn Gear for duty cycle analysis.

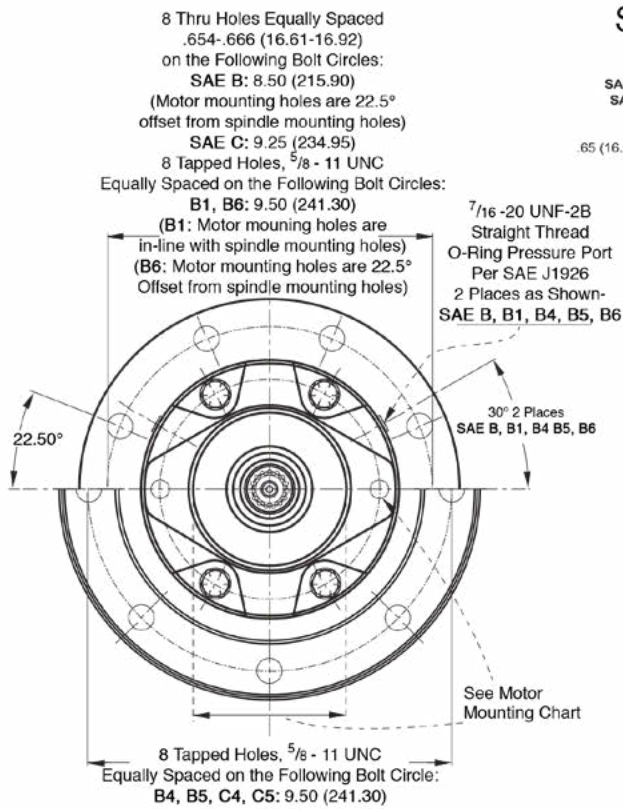

SAE B, B1, B6, C

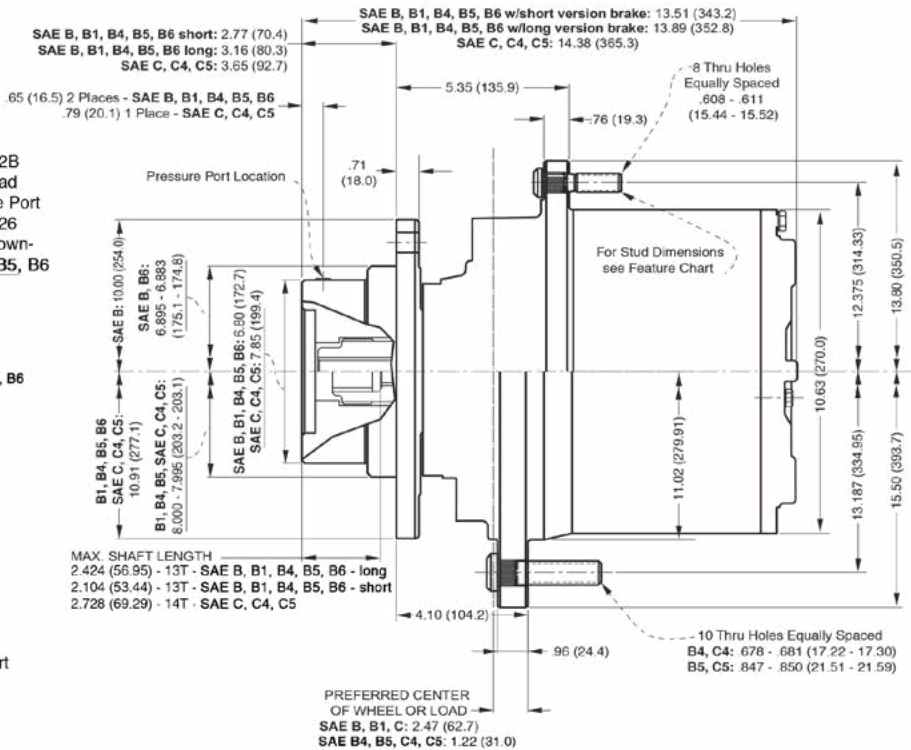

Dimensions given in: INCHES (mm)

SAE B4, B5, C4, C5

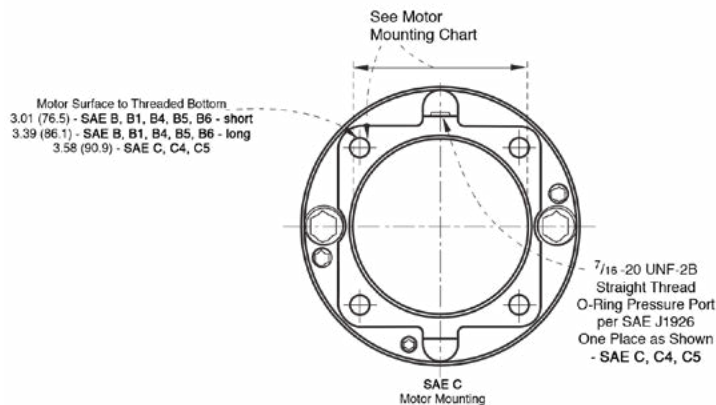

NON-POWERED UNITS ARE ALSO AVAILABLE

Model 8 Wheel Drives with A2 Series Parking Brake

FEATURE CHART: Model 8 Wheel Drives Double Reduction With Brake						
OPTIONS	DESCRIPTION	MAKE ALL SELECTIONS WITHIN ONE COLUMN		ORDER CODES	USE OPTION ORDER CODES TO BUILD ORDER NUMBER	
MOTOR PILOT/HUB	SAE B	•		8WB	8WB	
	B1	•		8WB1		
	B4	•		8WB4		
	B5	•		8WB5		
	B6	•		8WB6		
	SAE C		•	8WC		
	C4		•	8WC4		
	C5		•	8WC5		
INPUT SPLINE	13T - 16/32	•		13	13	
	14T - 12/24	•	•	14		
	15T - 16/32	•		15		
RATIO OPTIONS	14.39:1	•	•	14		
	17.83:1	•	•	17		
	22.59:1	•	•	22	22	
	25.71:1	•	•	25		
	30.50:1	•	•	30		
	34.20:1	•	•	34		
	41.42:1	•	•	41		
49.00:1	•	•	49			
WHEEL STUDS	1/2" x 2.50	•	•	5		
	9/16" x 2.75	•	•	7		
	5/8" x 2.37	•	•	8	8	
	3/4" x 3.21*	•	•	11		
	NONE	•	•	0		
PARKING BRAKE	SHORT VERSION	•		B2		
	1,800 lb-in	•		B3		
	2,400 lb-in					
	LONG VERSION	•	•	B4		
	2,400 lb-in	•	•	B5		
	3,200 lb-in	•	•	B6		
3,600 lb-in	•	•	B6			
4,200 lb-in	•	•	B7		B7	
SPECIAL FEATURES	Brake Disc**	•	•	D		
	Boot Seal	•	•	Z		Z
	Brake Disc Holes	•	•	DH		
	Quick Disconnect	•	•	Q		
	Oil Plugs/Spindle Side	•	•	P		
	High Strength Carrier	•	•	Y		
Cartridge Seal	•	•	T			

Select desired characteristics from chart, note correct order codes, and order using sample format shown at right: **8WB 13 22 8 B7 Z**

* Available with B5 and C5 mounting only

** Customer supplied, Auburn Gear assembled

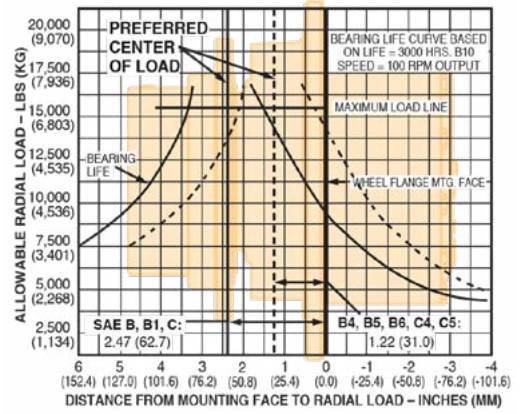

NOTE:

These curves are supplied as a design guide and apply to resultant radial load only. They indicate the importance of maintaining wheel position over the bearing center. For actual analysis, applications should be reviewed by Auburn Gear Engineering using data supplied on Application Data Form.

Bearing Load, Life, and Speed Relationships

$$LF = \frac{SF \times R}{R'}$$

R = Allowable resultant load or given location from mounting flange
 R' = Anticipated load at location from mounting flange
 LF = Life Factor from table (see Below)
 SF = Speed Factor from Table (see Below)

OUTPUT SPEED (RPM)	SF	LF	BEARING HOURS B-10 LIFE
5	2.456	0.584	500
10	1.994	0.719	1000
20	1.620	0.812	1500
30	1.435	0.886	2000
40	1.316	0.947	2500
50	1.231	1.000	3000
60	1.165	1.047	3500
70	1.113	1.090	4000
80	1.069	1.130	4500
90	1.032	1.166	5000
100	1.000	1.231	6000
200	0.812	1.289	7000
300	0.719	1.342	8000
400	0.659	1.390	9000
500	0.617	1.435	10000

CAUTION: The same torsional loading constraints used in the driving mode must be used in the braking mode when braking through the Power Wheel drive gear set.

NOTE:

The data presented in this catalog is for general information and preliminary layout purposes only. Auburn Gear, through its policy of continual improvement, reserves the right to update its products; therefore, the information presented is subject to change. For specific application and/or dimensional information, contact Auburn Gear.

MOTOR MOUNTING CHART

MOTOR MOUNTING HOLE DIMENSIONS	DIAMETER
SAE B, B1, B4, B5, B6: (2) - 1/2" -13 UNC 2B Thd Holes on 5.750 (146.05) B. C.	Ø 4.001 - 4.006 (101.62 - 101.75)
SAE C, C4, C5: (4) - 1/2" -13 UNC 2B Thd Holes on 6.375 (161.93) B. C.	Ø 5.001 - 5.006 (127.02 - 127.15)

+ "O" RING OR GASKET REQUIRED (Not Supplied by Auburn Gear)
 "O" RING SIZES: SAE "B" 2-155 (614120), SAE "C" 2-159 (614136)

Model 8 Shaft Output Drives • Single & Double Reductions

GENERAL SPECIFICATIONS

Single Reduction Drives

Max. intermittent output torque^{1,2}.....60,000 lb-in (6,780 Nm)
 Max. input speed².....3,500 RPM

Approximate Weight.....119 lbs (54 kg)
 Oil Capacity.....40 oz (1,200 cc)

Double Reduction Drives

Max. intermittent output torque^{1,2}.....100,000 lb-in (11,300 Nm)
 Max. input speed².....5,000 RPM

Approximate Weight.....155 lbs (70.3 kg)
 Oil Capacity.....55 oz (1,600 cc)

For Lubrication Data, See Pages 18-19

¹ Depending on the duty cycle and the nature of the application, a normal continuous output torque of 1/3 to 1/2 of the maximum intermittent should yield satisfactory Power Wheel life. Customer testing and application analysis is strongly recommended.

² If application exceeds published limits, contact Auburn Gear.

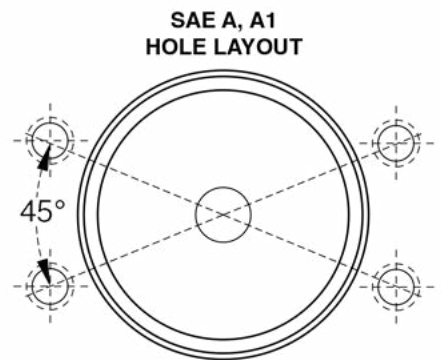
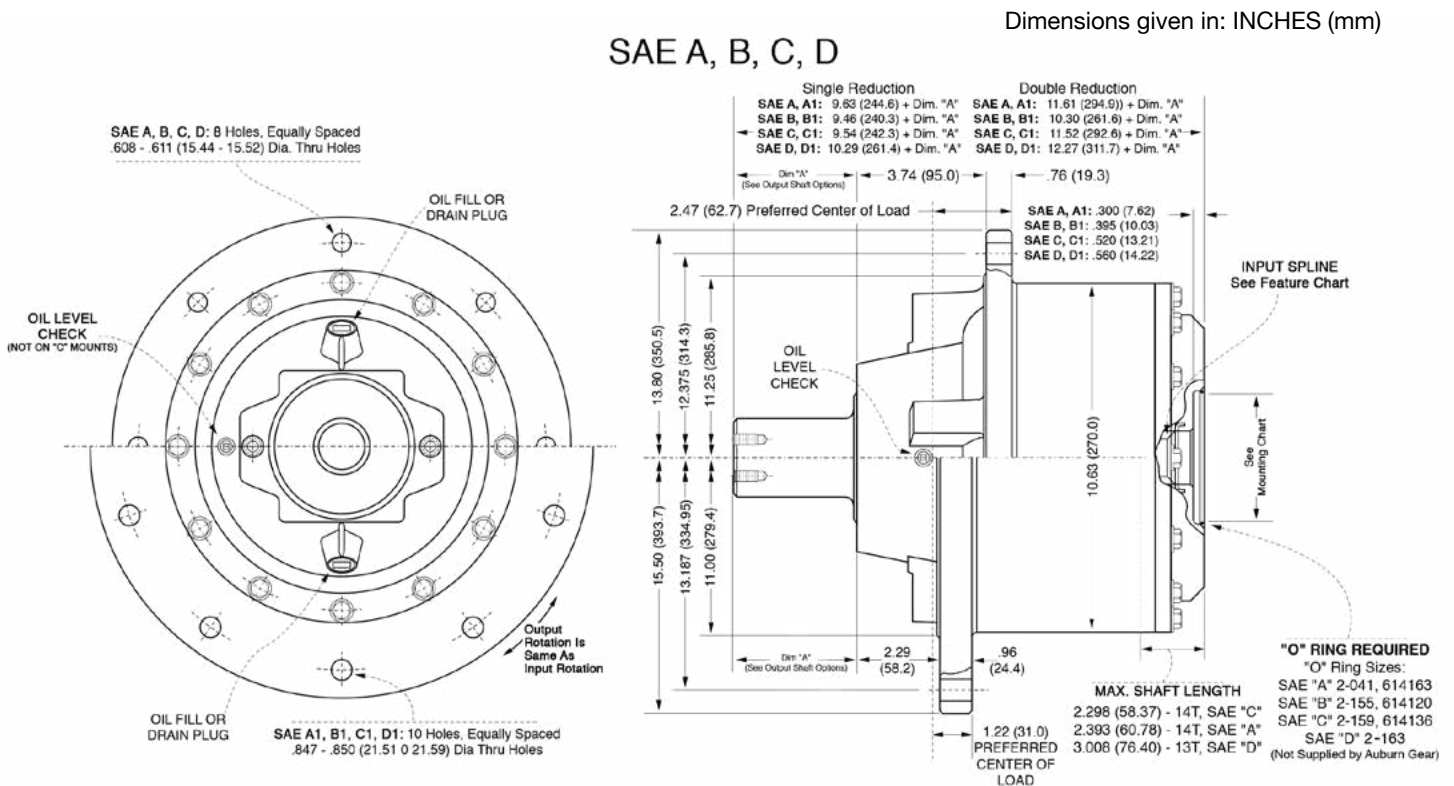

MOTOR MOUNTING CHART

MOTOR MOUNTING HOLE DIMENSIONS	DIAMETER
SAE A, A1: (4) - 1/2" -13 UNC 2B Thd Holes on 4.188 (106.38) B. C.	Ø 3.251 - 3.256 (82.58 - 82.70)
SAE B, B1: (2) - 1/2" -13 UNC 2B Thd Holes on 5.750 (146.05) B. C.	Ø 4.001 - 4.006 (101.62 - 101.75)
SAE C, C1: (4) - 1/2" -13 UNC 2B Thd Holes on 6.375 (161.93) B. C. OR (2) - 5/8" -11 UNC 2B Thd Holes on 7.125 (180.98) B. C.	Ø 5.001 - 5.006 (127.02 - 127.15)
SAE D, D1: (4) - 3/4" -10 UNC 2B Thd Holes on 9.000 (228.60) B. C.	Ø 6.001 - 6.006 (152.43 - 152.55)

+ "O" RING OR GASKET REQUIRED (Not Supplied by Auburn Gear)
"O" RING SIZES: SAE "A" 2-042 (614163), SAE "B" 2-155 (614120), SAE "C" 2-159 (614136), SAE "D" 2-163

Model 8 Shaft Output Drives

FEATURE CHART: Model 8 Shaft Output Drives - Single Reduction

OPTIONS	DESCRIPTION	MAKE ALL SELECTIONS WITHIN ONE COLUMN				ORDER CODES	USE OPTION ORDER CODES TO BUILD ORDER NUMBER			
MOTOR PILOT/HUB	SAE A	•				8TA				
	A1	•				8TA1				
	SAE B	•	•			8TB				
	B1	•	•			8TB1				
	SAE C	•		•		8TC	8TC			
	C1	•		•		8TC1				
INPUT SPLINE	13T - 8/16"		•			13			14	
	14T - 12/24"	•				14				
	17T - 12/24"			•		17				
RATIO OPTIONS	3.92:1	•	•	•		03				
	4.86:1	•				04				
	5.50:1	•				05				
	6.00:1	•	•	•		06				
	7.07:1	•	•	•		07			07	
OUTPUT SHAFTS	23T - 12/24	•	•	•		23				K1
	2.0" Keyed	•	•	•		K1				
	3.0" Keyed	•	•	•		K2				
	2 15/16" Keyed	•	•	•		K5				
	20T - 8/16	•	•	•		20				
	21T - 8/16 Female	•	•	•		21				
	23T - 8/16	•	•	•		23S				
	23T - 8/16	•	•	•		23L				
	2.0" Round	•	•	•		A1				
	2.56" Round	•	•	•		A2				
	2.0" Hex	•	•	•		H1				
	2.0" Hex	•	•	•		H2				
	Spindle	•	•	•		F1				
	Spindle	•	•	•		F2				
Spindle	•	•	•		F3					
Spindle	•	•	•		F5					

Select desired characteristics from chart, note correct order codes, and order using sample format shown at right:

8TC 14 07 K1

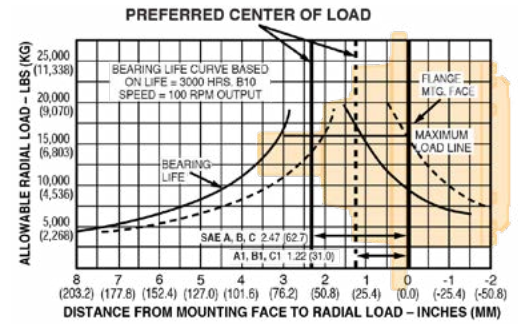

NOTE:

These curves are supplied as a design guide and apply to resultant radial load only. They indicate the importance of maintaining wheel position over the bearing center. For actual analysis, applications should be reviewed by Auburn Gear Engineering using data supplied on Application Data Form.

FEATURE CHART: Model 8 Shaft Output Drives - Double Reduction

OPTIONS	DESCRIPTION	MAKE ALL SELECTIONS WITHIN ONE COLUMN				ORDER CODES	USE OPTION ORDER CODES TO BUILD ORDER NUMBER			
MOTOR PILOT/HUB	SAE A	•				8SA				
	A1	•				8SA1				
	SAE B	•	•			8SB	8SB			
	B1	•	•			8SB1				
	SAE C	•		•		8SC				
	C1	•		•		8SC1				
INPUT SPLINE	13T - 16/32"		•			13			13	
	13T - 8/16"			•		13				
	14T - 12/24"	•		•		14				
RATIO OPTIONS*	15.29:1	•	•	•	•	15				
	18.83:1	•	•	•	•	18				
	23.59:1	•	•	•	•	23				
	26.71:1	•	•	•	•	26				
	31.50:1	•	•	•	•	31				
	35.20:1	•	•	•	•	35				
	42.42:1	•	•	•	•	42			42	
	50.00:1	•	•	•	•	50				
OUTPUT SHAFTS	23T - 12/24	•	•	•	•	23				20
	2.0" Keyed	•	•	•	•	K1				
	3.0" Keyed	•	•	•	•	K2				
	2 15/16" Keyed	•	•	•	•	K5				
	20T - 8/16	•	•	•	•	20				
	21T - 8/16 Female	•	•	•	•	21				
	23T - 8/16	•	•	•	•	23S				
	23T - 8/16	•	•	•	•	23L				
	2.0" Round	•	•	•	•	A1				
	2.56" Round	•	•	•	•	A2				
	2.0" Hex	•	•	•	•	H1				
	2.0" Hex	•	•	•	•	H2				
	Spindle	•	•	•	•	F1				
	Spindle	•	•	•	•	F2				
Spindle	•	•	•	•	F3					
Spindle	•	•	•	•	F5					

Select desired characteristics from chart, note correct order codes, and order using sample format shown at right:

8SB 13 42 20

Bearing Load, Life, and Speed Relationships

$$LF = \frac{SF \times R}{R'}$$

R = Allowable resultant load or given location from mounting flange
 R' = Anticipated load at location from mounting flange
 LF = Life Factor from table (see Below)
 SF = Speed Factor from Table (see Below)

OUTPUT SPEED (RPM)	SF	LF	BEARING HOURS B-10 LIFE
5	2.456	0.584	500
10	1.994	0.719	1000
20	1.620	0.812	1500
30	1.435	0.886	2000
40	1.316	0.947	2500
50	1.231	1.000	3000
60	1.165	1.047	3500
70	1.113	1.090	4000
80	1.069	1.130	4500
90	1.032	1.166	5000
100	1.000	1.231	6000
200	0.812	1.289	7000
300	0.719	1.342	8000
400	0.659	1.390	9000
500	0.617	1.435	10000

CAUTION: The same torsional loading constraints used in the driving mode must be used in the braking mode when braking through the Power Wheel drive gear set.

NOTE:

The data presented in this catalog is for general information and preliminary layout purposes only. Auburn Gear, through its policy of continual improvement, reserves the right to update its products; therefore, the information presented is subject to change. For specific application and/or dimensional information, contact Auburn Gear.

*Triple reduction ratios available: 70.61:1-183.02:1; deeper ratios also available. Contact Auburn Gear.

Model 8 Shaft Output Drives • Single & Double Reductions with A2 Series Integral Parking Brake¹

GENERAL SPECIFICATIONS

Max. intermittent output torque^{2,3}.....100,000 lb-in (11,300 Nm)
Max. input speed⁴.....3,500 RPM

Approximate Weight.....185 lbs (83.9 kg)
Oil Capacity.....54 oz (1,597 cc)

For Lubrication Data, See Pages 18-19

¹For vertical applications, shaft up or down, contact Auburn Gear.

²Depending on the duty cycle and the nature of the application, a normal continuous output torque of 1/3 to 1/2 of the maximum intermittent should yield satisfactory Power Wheel life. Customer testing and application analysis is strongly recommended.

³If application exceeds published limits, contact Auburn Gear.

⁴For input speeds above 3,500 RPM please contact Auburn Gear for duty cycle analysis.

Dimensions given in: INCHES (mm)

SAE A, B, C

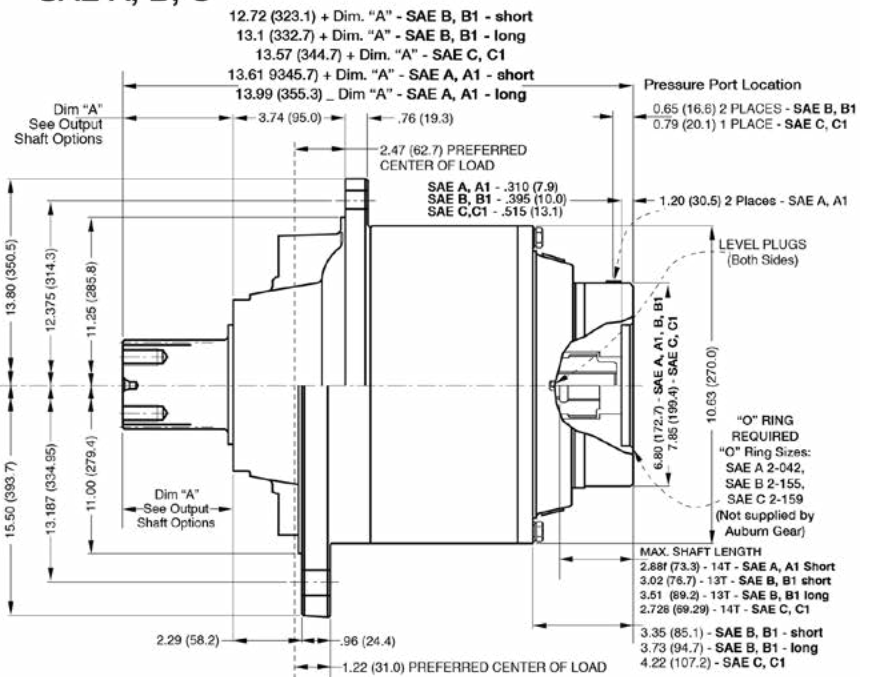
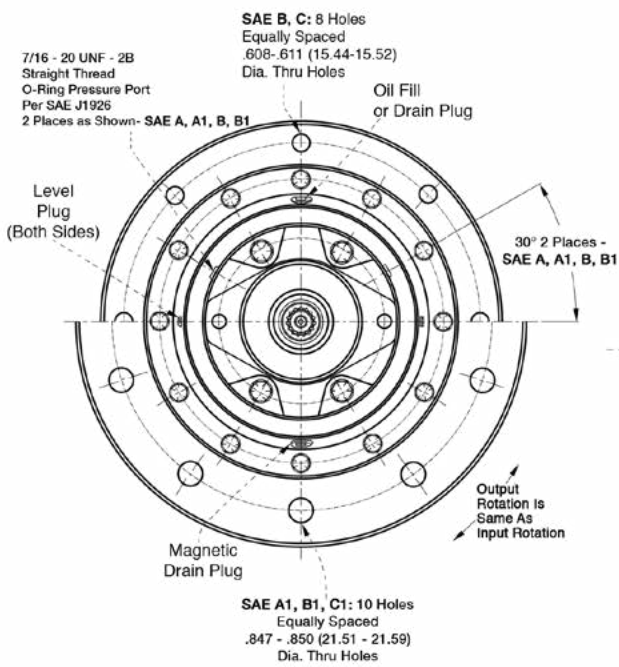

SAE A1, B1, C1

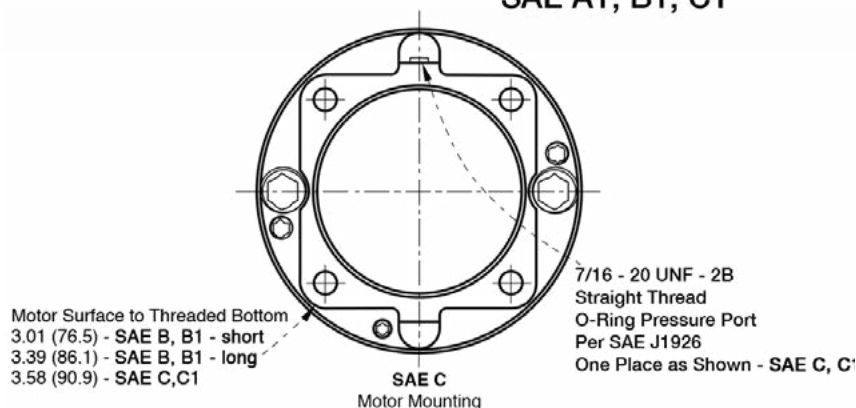

Model 8 Shaft Output Drives with A2 Series Parking Brake

FEATURE CHART: Model 8 Shaft Output Double Reduction With Brake

OPTIONS	DESCRIPTION	MAKE ALL SELECTIONS WITHIN ONE COLUMN		ORDER CODES	USE OPTION ORDER CODES TO BUILD ORDER NUMBER			
MOTOR PILOT/HUB	SAE A	•		8SA	8SC			
	A1	•		8SA1				
	SAE B	•		8SB				
	B1	•		8SB1				
	SAE C		•	8SC				
C1			•	8SC1				
INPUT SPLINE	13T - 16/32"	•		13	14			
	14T - 12/24"	•	•	14				
RATIO OPTIONS	15.39:1	•	•	15	23			
	18.83:1	•	•	18				
	23.59:1	•	•	23				
	26.71:1	•	•	26				
	31.50:1	•	•	31				
	35.20:1	•	•	35				
	42.42:1	•	•	42				
	50.00:1	•	•	50				
OUTPUT SHAFTS	23T - 12/24	•	•	23	20			
	2.0" Keyed	•	•	K1				
	3.0" Keyed	•	•	K2				
	2 15/16" Keyed	•	•	K5				
	20T - 8/16	•	•	20				
	21T - 8/16 Female	•	•	21				
	23T - 8/16	•	•	23S				
	23T - 8/16	•	•	23L				
	2.0" Round	•	•	A1				
	2.56" Round	•	•	A2				
	2.0" Hex	•	•	H1				
	2.0" Hex	•	•	H2				
	Spindle	•	•	F1				
	Spindle	•	•	F2				
Spindle	•	•	F3					
Spindle	•	•	F5					
PARKING BRAKE	SHORT VERSION	•		B2				
	1,800 lb-in							
	2,400 lb-in	•	•	B4				
	LONG VERSION							
	2,400 lb-in							
	3,200 lb-in							
	3,600 lb-in							
4,200 lb-in	B7							

Select desired characteristics from chart, note correct order codes, and order using sample format shown at right:

8SC 14 23 20 B7

MOTOR MOUNTING CHART

MOTOR MOUNTING HOLE DIMENSIONS	DIAMETER
SAE A, A1: (2) - 3/8" -16 UNC - 2B Thd Holes on 4.187 (106.35) B. C. AND (4) - 1/2" -13 UNC- 2B Thd Holes on 4.187 (106.35) B. C.	Ø 3.251 - 3.256 (82.58 - 82.70)
SAE B, B1: (2) - 1/2" -13 UNC - 2B Thd Holes on 5.750 (146.05) B. C.	Ø 4.001 - 4.006 (101.62 - 101.75)
SAE C, C1: (2) - 1/2" -13 UNC - 2B Thd Holes on 6.375 (161.93) B. C.	Ø 5.001 - 5.006 (127.02 - 127.15)

*"O" RING OR GASKET REQUIRED (Not Supplied by Auburn Gear) "O" RING SIZES:
SAE "A" 2-042 (614163), SAE "B" 2-155 (614120), SAE "C" 2-159 (614136)

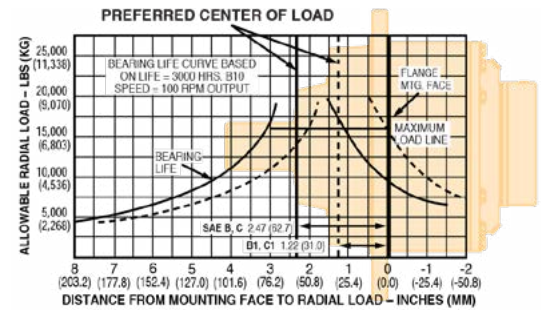

NOTE:

These curves are supplied as a design guide and apply to resultant radial load only. They indicate the importance of maintaining wheel position over the bearing center. For actual analysis, applications should be reviewed by Auburn Gear Engineering using data supplied on Application Data Form.

Bearing Load, Life, and Speed Relationships

$$LF = \frac{SF \times R}{R'}$$

R = Allowable resultant load or given location from mounting flange
R' = Anticipated load at location from mounting flange
LF = Life Factor from table (see Below)
SF = Speed Factor from Table (see Below)

OUTPUT SPEED (RPM)	SF	LF	BEARING HOURS B-10 LIFE
5	2.456	0.584	500
10	1.994	0.719	1000
20	1.620	0.812	1500
30	1.435	0.886	2000
40	1.316	0.947	2500
50	1.231	1.000	3000
60	1.165	1.047	3500
70	1.113	1.090	4000
80	1.069	1.130	4500
90	1.032	1.166	5000
100	1.000	1.231	6000
200	0.812	1.289	7000
300	0.719	1.342	8000
400	0.659	1.390	9000
500	0.617	1.435	10000

CAUTION: The same torsional loading constraints used in the driving mode must be used in the braking mode when braking through the Power Wheel drive gear set.

NOTE:

The data presented in this catalog is for general information and preliminary layout purposes only. Auburn Gear, through its policy of continual improvement, reserves the right to update its products; therefore, the information presented is subject to change. For specific application and/or dimensional information, contact Auburn Gear.

Model 8 Flangeless Hub Shaft & Flanged Output Drives

• Single & Double Reductions

GENERAL SPECIFICATIONS

Single Reduction Drives

Max. intermittent output torque^{1,2}.....60,000 lb-in (6,780 Nm)
 Max. input speed².....3,500 RPM

Approximate Weight.....119 lbs (54 kg)
 Oil Capacity.....40 oz (1,200 cc)

Double Reduction Drives

Max. intermittent output torque^{1,2}.....100,000 lb-in (11,300 Nm)
 Max. input speed².....5,000 RPM

Approximate Weight.....155 lbs (70.3 kg)
 Oil Capacity.....55 oz (1,600 cc)

For Lubrication Data, See Pages 18-19

¹ Depending on the duty cycle and the nature of the application, a normal continuous output torque of 1/3 to 1/2 of the maximum intermittent should yield satisfactory Power Wheel life. Customer testing and application analysis is strongly recommended.

² If application exceeds published limits, contact Auburn Gear.

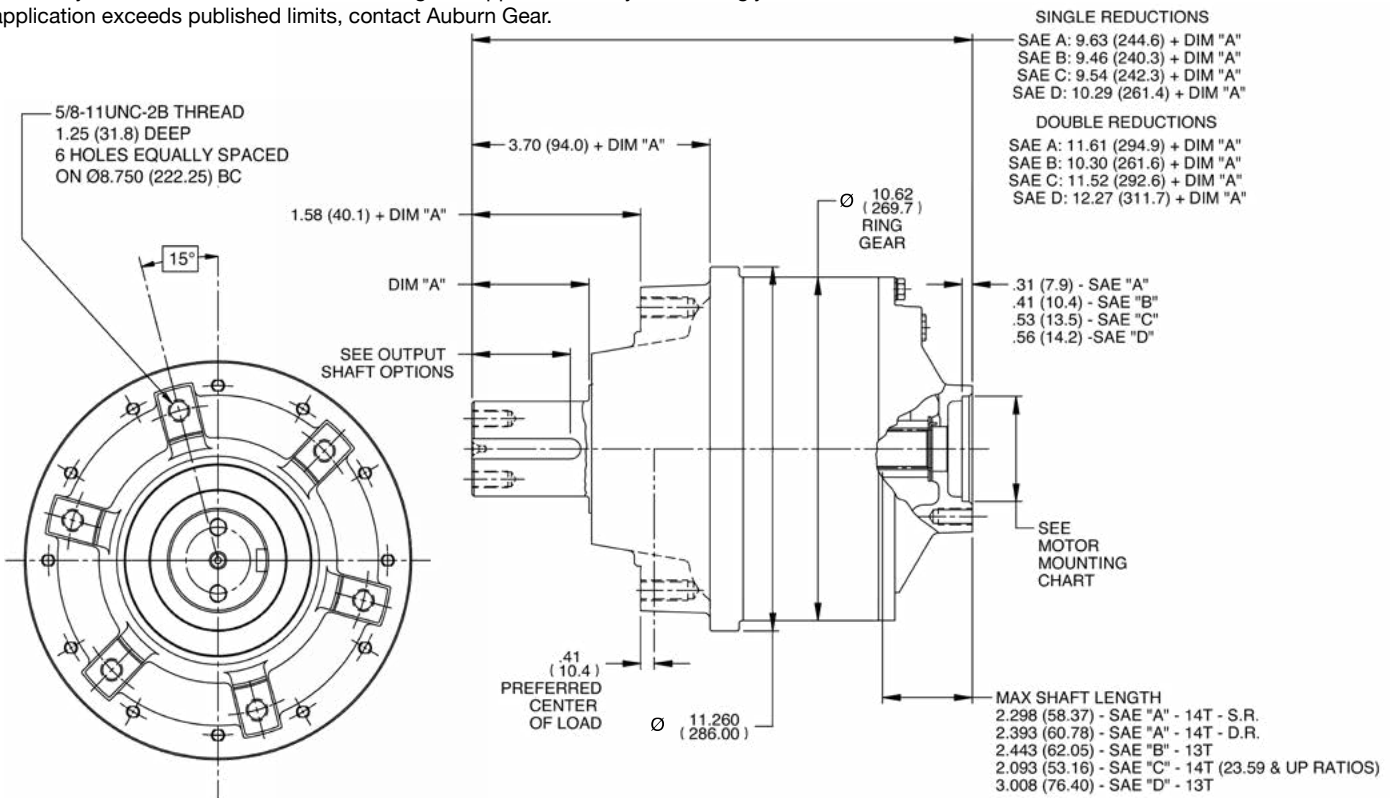

SAE A, A1 HOLE LAYOUT

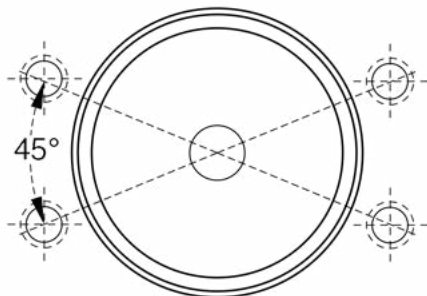

MOTOR MOUNTING CHART

MOTOR MOUNTING HOLE DIMENSIONS	DIAMETER
SAE A, A1: (4) - 1/2" -13 UNC 2B Thd Holes on 4.188 (106.38) B. C.	Ø 3.251 - 3.256 (82.58 - 82.70)
SAE B, B1: (2) - 1/2" -13 UNC 2B Thd Holes on 5.750 (146.05) B. C.	Ø 4.001 - 4.006 (101.62 - 101.75)
SAE C, C1: (4) - 1/2" -13 UNC 2B Thd Holes on 6.375 (161.93) B. C. OR (2) - 5/8" -11 UNC 2B Thd Holes on 7.125 (180.98) B. C.	Ø 5.001 - 5.006 (127.02 - 127.15)
SAE D, D1: (4) - 3/4" -10 UNC 2B Thd Holes on 9.000 (228.60) B. C.	Ø 6.001 - 6.006 (152.43 - 152.55)

+ "O" RING OR GASKET REQUIRED (Not Supplied by Auburn Gear)
 "O" RING SIZES: SAE "A" 2-042 (614163), SAE "B" 2-155 (614120),
 SAE "C" 2-159 (614136), SAE "D" 2-163

FEATURE CHART: Model 8 Flangeless Shaft Output Drives - Single Reduction

OPTIONS	DESCRIPTION	MAKE ALL SELECTIONS WITHIN ONE COLUMN				ORDER CODES	USE OPTION ORDER CODES TO BUILD ORDER NUMBER			
MOTOR PILOT/HUB	SAE A	•				8FA				
	A1	•				8FA1				
	SAE B	•	•			8FB				
	B1	•	•			8FB1				
	SAE C	•		•		8FC	8FC			
	C1	•		•		8FC1				
INPUT SPLINE	SAE D	•		•		8FD				
	D1	•		•		8FD1				
	13T - 8/16		•			13			14	
RATIO OPTIONS	14T - 12/24		•			14				
	17T - 12/24		•			17				
	3.92:1	•	•	•		03				
OUTPUT SHAFTS	4.86:1	•				04				
	5.50:1	•				05				
	6.00:1	•	•	•		06				
	7.07:1	•	•	•		07			07	
	23T - 12/24	•	•	•		23				K1
	2.0" Keyed	•	•	•		K1				
	3.0" Keyed	•	•	•		K2				
2 15/16" Keyed	•	•	•		K5					
20T - 8/16	•	•	•		20					
21T - 8/16 Female	•	•	•		21					
23T - 8/16	•	•	•		23S					
23T - 8/16	•	•	•		23L					
2.0" Round	•	•	•		A1					
2.56" Round	•	•	•		A2					
2.0" Hex	•	•	•		H1					
2.0" Hex	•	•	•		H2					
Spindle	•	•	•		F1					
Spindle	•	•	•		F2					
Spindle	•	•	•		F3					
Spindle	•	•	•		F5					

Select desired characteristics from chart, note correct order codes, and order using sample format shown at right:

8FC 14 07 K1

FEATURE CHART: Model 8 Flangeless Shaft Output Drives - Double Reduction

OPTIONS	DESCRIPTION	MAKE ALL SELECTIONS WITHIN ONE COLUMN				ORDER CODES	USE OPTION ORDER CODES TO BUILD ORDER NUMBER			
MOTOR PILOT/HUB	SAE A	•				8FA				
	A1	•				8FA1				
	SAE B	•	•			8FB	8FB			
	B1	•	•			8FB1				
	SAE C	•		•		8FC				
	C1	•		•		8FC1				
INPUT SPLINE	SAE D	•		•		8FD				
	D1	•		•		8FD1				
	13T - 16/32		•			13			13	
RATIO OPTIONS*	13T - 8/16		•			13				
	14T - 12/24		•			14				
	15.29:1	•	•	•		15				
	18.83:1	•	•	•		18				
	23.59:1	•	•	•		23				
	26.71:1	•	•	•		26				
	31.50:1	•	•	•		31				
	35.20:1	•	•	•		35				
42.42:1	•	•	•		42			42		
OUTPUT SHAFTS	50.00:1	•	•	•		50				
	23T - 12/24	•	•	•		23				
	2.0" Keyed	•	•	•		K1				
	3.0" Keyed	•	•	•		K2				
	2 15/16" Keyed	•	•	•		K5				
	20T - 8/16	•	•	•		20				
	21T - 8/16 Female	•	•	•		21				20
	23T - 8/16	•	•	•		23S				
	23T - 8/16	•	•	•		23L				
	2.0" Round	•	•	•		A1				
	2.56" Round	•	•	•		A2				
	2.0" Hex	•	•	•		H1				
	2.0" Hex	•	•	•		H2				
	Spindle	•	•	•		F1				
Spindle	•	•	•		F2					
Spindle	•	•	•		F3					
Spindle	•	•	•		F5					

Select desired characteristics from chart, note correct order codes, and order using sample format shown at right:

8FB 13 42 20

*Triple reduction ratios available: 70.61:1-183.02:1; deeper ratios also available. Contact Auburn Gear.

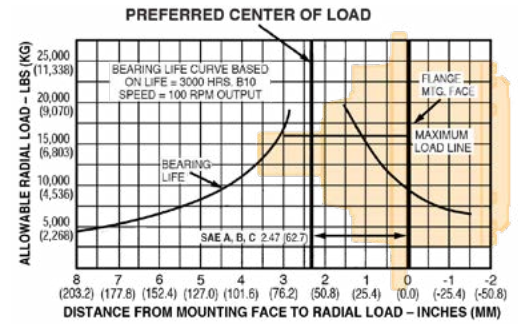

NOTE:

These curves are supplied as a design guide and apply to resultant radial load only. They indicate the importance of maintaining wheel position over the bearing center. For actual analysis, applications should be reviewed by Auburn Gear Engineering using data supplied on Application Data Form.

Bearing Load, Life, and Speed Relationships

$$LF = \frac{SF \times R}{R'}$$

R = Allowable resultant load or given location from mounting flange
 R' = Anticipated load at location from mounting flange
 LF = Life Factor from table (see Below)
 SF = Speed Factor from Table (see Below)

OUTPUT SPEED (RPM)	SF	LF	BEARING HOURS B-10 LIFE
5	2.456	0.584	500
10	1.994	0.719	1000
20	1.620	0.812	1500
30	1.435	0.886	2000
40	1.316	0.947	2500
50	1.231	1.000	3000
60	1.165	1.047	3500
70	1.113	1.090	4000
80	1.069	1.130	4500
90	1.032	1.166	5000
100	1.000	1.231	6000
200	0.812	1.289	7000
300	0.719	1.342	8000
400	0.659	1.390	9000
500	0.617	1.435	10000

CAUTION: The same torsional loading constraints used in the driving mode must be used in the braking mode when braking through the Power Wheel drive gear set.

NOTE:

The data presented in this catalog is for general information and preliminary layout purposes only. Auburn Gear, through its policy of continual improvement, reserves the right to update its products; therefore, the information presented is subject to change. For specific application and/or dimensional information, contact Auburn Gear.

Model 8 Shaft Input/Shaft Output Drives • Single & Double Reductions

GENERAL SPECIFICATIONS

Single Reduction Drives

Max. intermittent output torque^{1,2}.....60,000 lb-in (6,780 Nm)
 Max. input speed².....3,500 RPM

Approximate Weight.....119 lbs (54 kg)
 Oil Capacity.....40 oz (1,200 cc)

Double Reduction Drives

Max. intermittent output torque^{1,2}.....100,000 lb-in (11,300 Nm)
 Max. input speed².....5,000 RPM

Approximate Weight.....155 lbs (70.3 kg)
 Oil Capacity.....55 oz (1,600 cc)

For Lubrication Data, See Pages 18-19

¹ Depending on the duty cycle and the nature of the application, a normal continuous output torque of 1/3 to 1/2 of the maximum intermittent should yield satisfactory Power Wheel life. Customer testing and application analysis is strongly recommended.

² If application exceeds published limits, contact Auburn Gear.

8S, 8T

Dimensions given in: INCHES (mm)

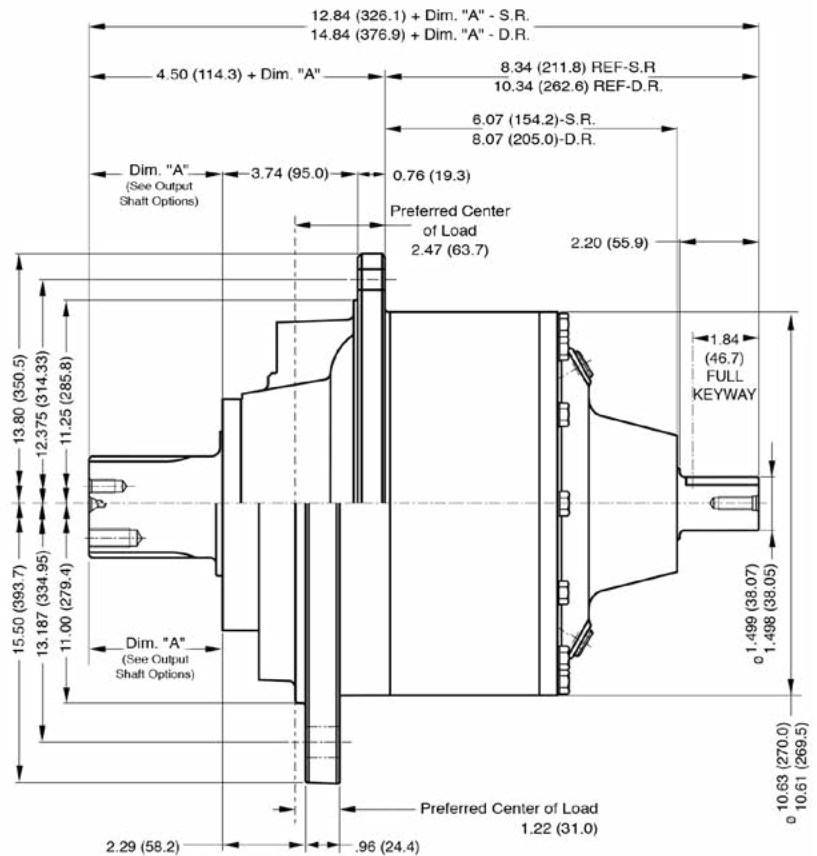

8S1, 8T1

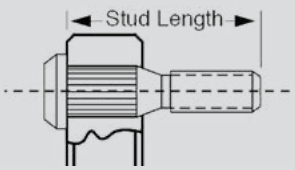
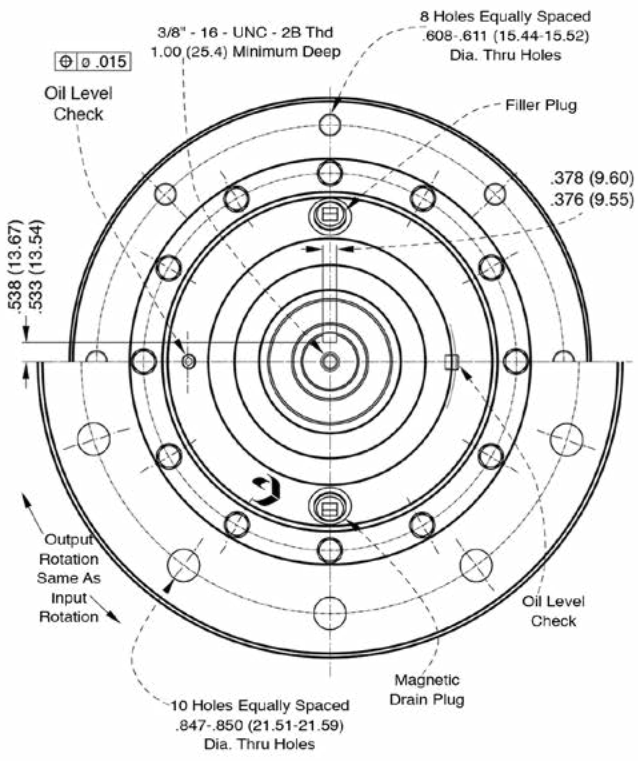

Wheel Stud – Detail

Note that the stud lengths shown in the feature chart represent the total length of the stud under the head.

FEATURE CHART: Model 8 Shaft Input/Shaft Output Drives - Single Reduction

OPTIONS	DESCRIPTION	MAKE ALL SELECTIONS WITHIN ONE COLUMN	ORDER CODES	USE OPTION ORDER CODES TO BUILD ORDER NUMBER
HUB	Small Flange	•	8T	8T
	Large Flange	•	8T1	
INPUT SPLINE	1 1/2" Keyed	•	K00	K00
RATIO OPTIONS	3.92:1	•	03	03
OUTPUT SHAFTS	23T - 12/24	•	23	20
	2.0" Keyed	•	K1	
	3.0" Keyed	•	K2	
	2 15/16 Keyed	•	K5	
	20T - 8/16	•	20	
	21T - 8/16 Female	•	21	
	23T - 8/16	•	23S	
	23T - 8/16	•	23L	

Select desired characteristics from chart, note correct order codes, and order using sample format shown at right: **8T K00 03 20**

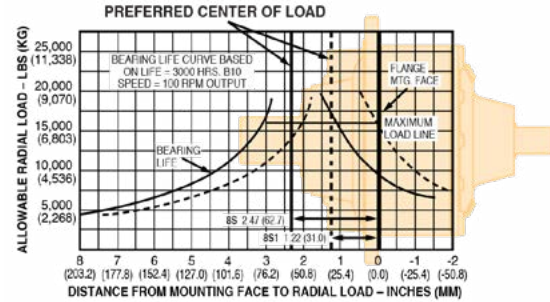

NOTE:

These curves are supplied as a design guide and apply to resultant radial load only. They indicate the importance of maintaining wheel position over the bearing center. For actual analysis, applications should be reviewed by Auburn Gear Engineering using data supplied on Application Data Form.

Bearing Load, Life, and Speed Relationships

$$LF = \frac{SF \times R}{R'}$$

R = Allowable resultant load at given location from mounting flange
 R' = Anticipated load at location from mounting flange
 LF = Life Factor from table (see Below)
 SF = Speed Factor from Table (see Below)

FEATURE CHART: Model 8 Shaft Input/Shaft Output Drives - Double Reduction

OPTIONS	DESCRIPTION	MAKE ALL SELECTIONS WITHIN ONE COLUMN	ORDER CODES	USE OPTION ORDER CODES TO BUILD ORDER NUMBER
HUB	Small Flange	•	8S	8S
	Large Flange	•	8S1	
INPUT SPLINE	1 1/2" Keyed	•	K00	K00
RATIO OPTIONS	15.39:1	•	15	23
	18.83:1	•	18	
	23.59:1	•	23	
	26.71:1	•	26	
	31.50:1	•	31	
	35.20:1	•	35	
	42.42:1	•	42	
	50.00:1	•	50	
OUTPUT SHAFTS	23T - 12/24	•	23	20
	2.0" Keyed	•	K1	
	3.0" Keyed	•	K2	
	2 15/16 Keyed	•	K5	
	20T - 8/16	•	20	
	21T - 8/16 Female	•	21	
	23T - 8/16	•	23S	
	23T - 8/16	•	23L	

Select desired characteristics from chart, note correct order codes, and order using sample format shown at right: **8S K00 23 20**

OUTPUT SPEED (RPM)	SF	LF	BEARING HOURS B-10 LIFE
5	2.456	0.584	500
10	1.994	0.719	1000
20	1.620	0.812	1500
30	1.435	0.886	2000
40	1.316	0.947	2500
50	1.231	1.000	3000
60	1.165	1.047	3500
70	1.113	1.090	4000
80	1.069	1.130	4500
90	1.032	1.166	5000
100	1.000	1.231	6000
200	0.812	1.289	7000
300	0.719	1.342	8000
400	0.659	1.390	9000
500	0.617	1.435	10000

CAUTION: The same torsional loading constraints used in the driving mode must be used in the braking mode when braking through the Power Wheel drive gear set.

NOTE:

The data presented in this catalog is for general information and preliminary layout purposes only. Auburn Gear, through its policy of continual improvement, reserves the right to update its products; therefore, the information presented is subject to change. For specific application and/or dimensional information, contact Auburn Gear.

Model 8 Shaft and Flanged Output Options

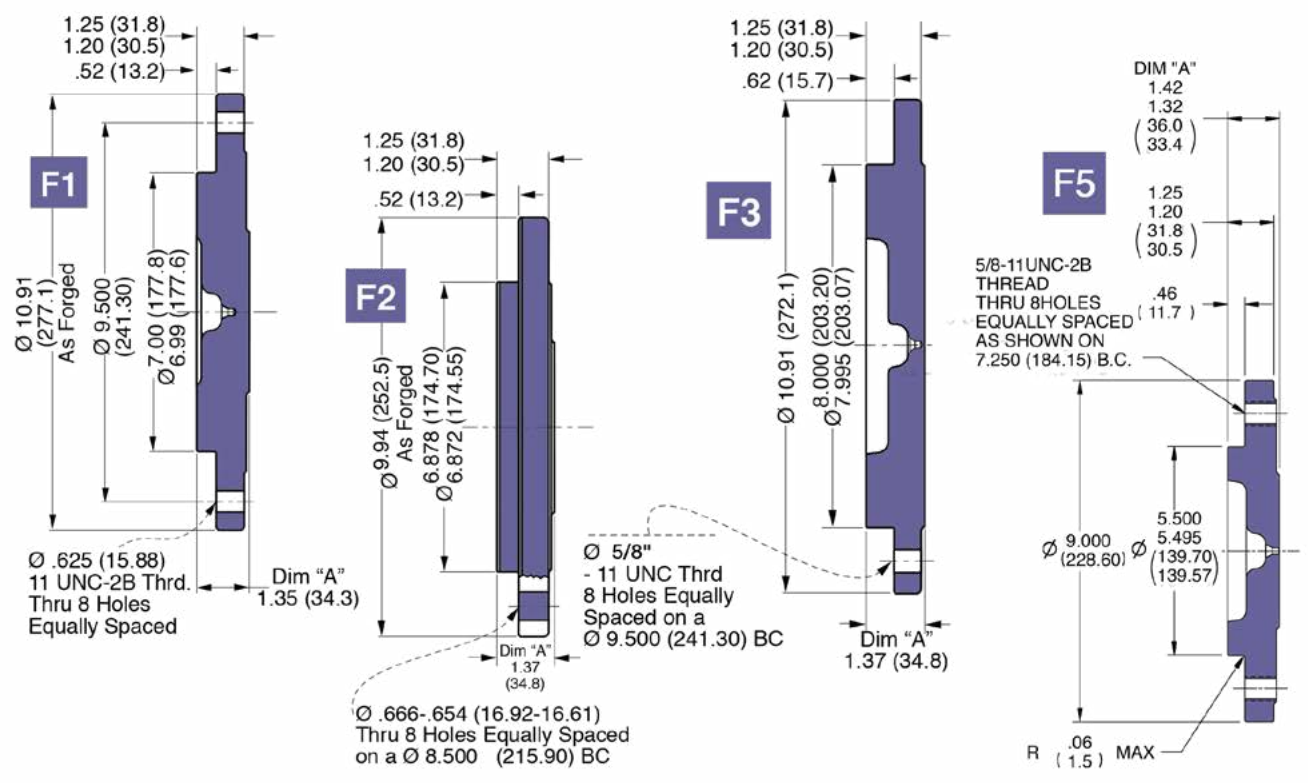
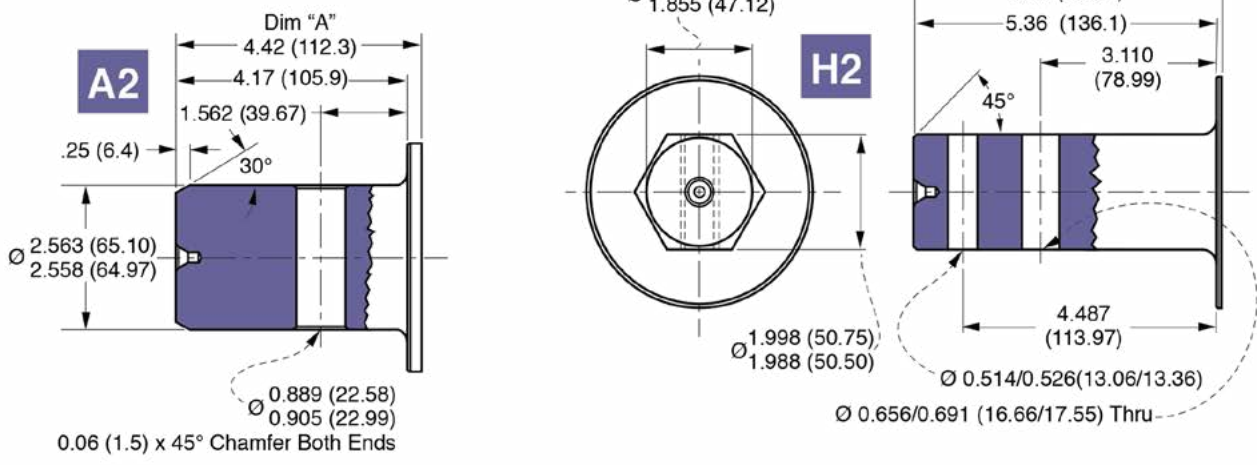
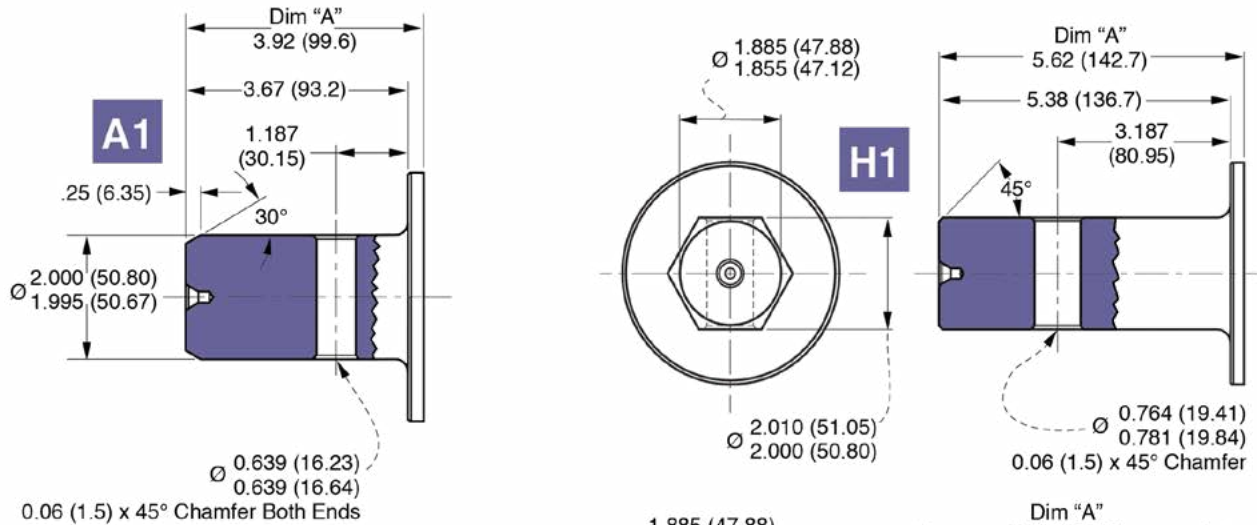

Model 8 Shaft and Flanged Output Drives

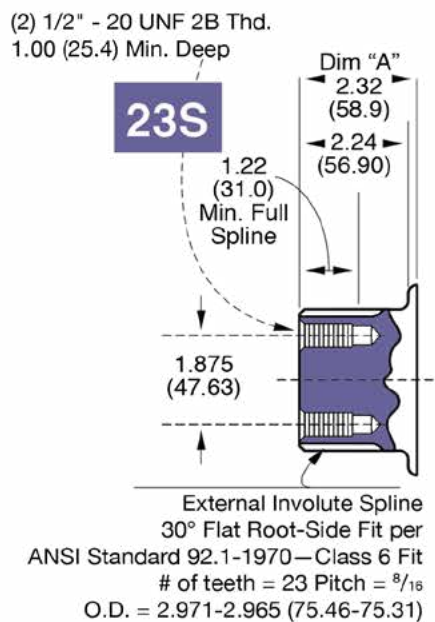
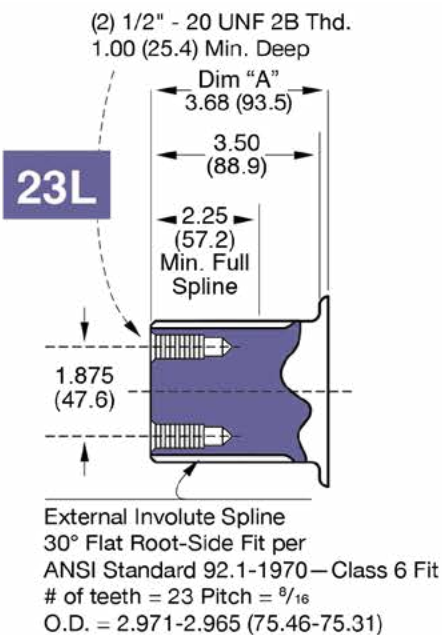
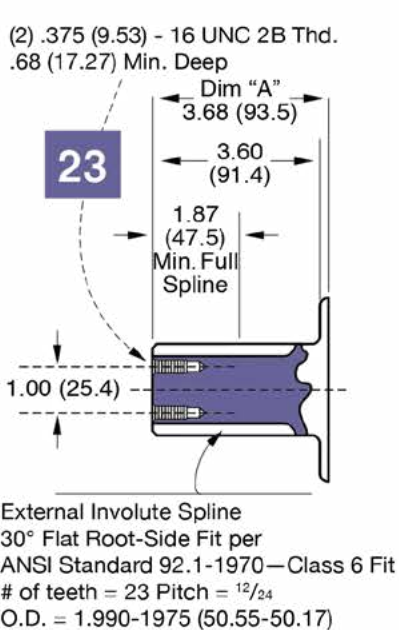
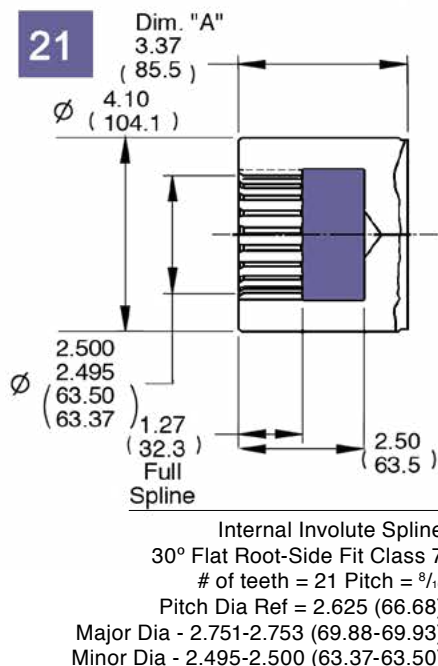
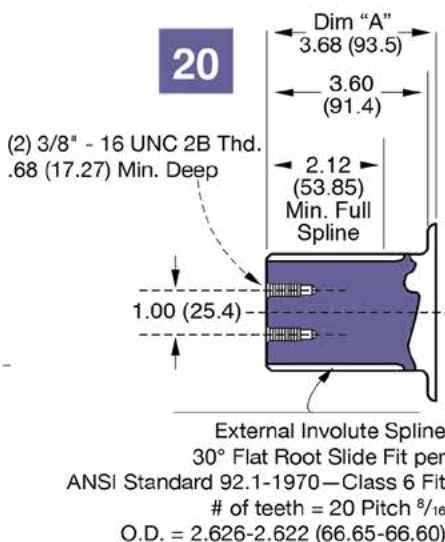
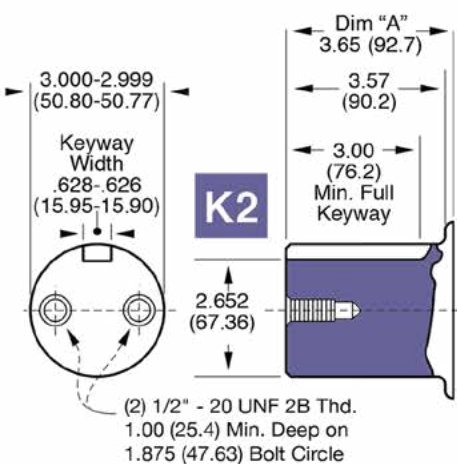
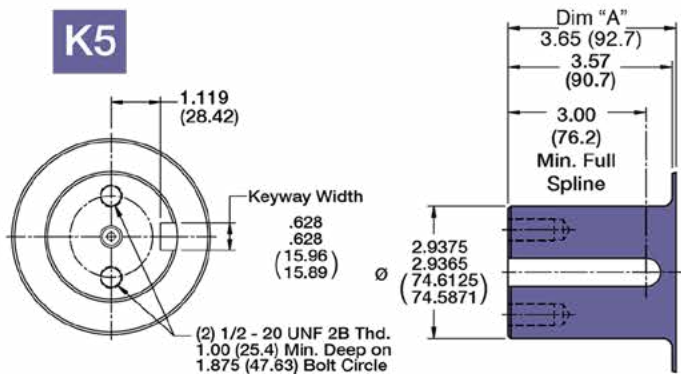
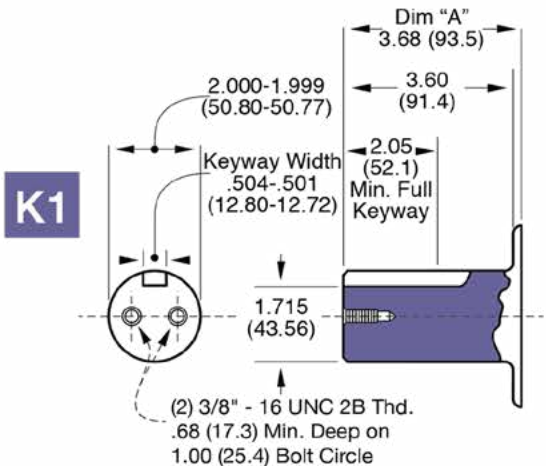

Model 8 Other Options

Weldable Hub

The hubs are 4140H steel and can be turned down and/or welded for mounting sprockets, pulleys, or other devices. A circular keeper plate secures the hub to the splined output shaft with two bolts (keeper plate and bolts included).

KIT NUMBER	SPLINE	FITS MODELS
6420105	23T - ¹² / ₂₄	5, 6, & 8
6420106	23T - ⁸ / ₁₆	6B, 7, 8B, 9, & 10
6420107	20T - ⁸ / ₁₆	8, 8B, & 9

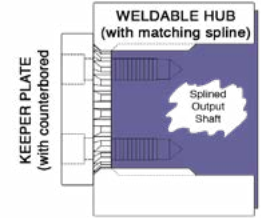

Boot Seal

An optional seal that protects the main oil seal from dirt and other debris. The boot seal will give extended life on applications operating in extremely muddy or dirty conditions. Boot seals are available on a selective model basis.

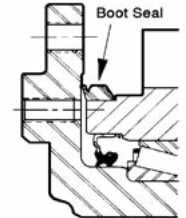

Guard and Boot Seal System

A boot seal and metal guard are available with F5 spindle output units only. These can be ordered separately or together. They function best together. The guard and boot seal system are utilized in extremely high grit applications. The guard protects the boot seal from contaminants which will ultimately wear the boot seal lip.

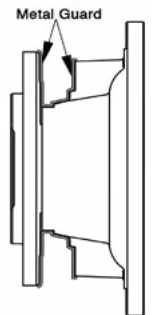

Quick Disconnect

This optional disconnect is available on all wheel drives. No tools are needed to disengage or re-engage the drive. The planetary drive is disengaged with the push of a button. The quick disconnect eliminates removal of the disconnect cover and external contaminants are sealed from the units by internal o-rings and a gasket that is sandwiched between the disconnect and planetary cover. The rugged, compact design ensures dependable service.

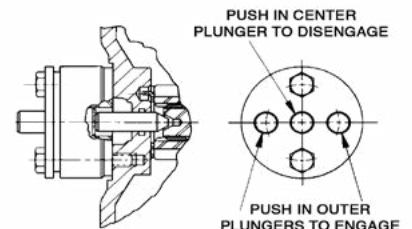

Lubrication Data

AUBURN GEAR POWER WHEEL LOW TEMPERATURE GEAR LUBE REQUIREMENT	
SAE Viscosity Grade	Auburn Gear Recommended Minimum Temperature
75W-90	-40°F (-40°C)*
80W, 80W-90	-15°F (-26°C)*
85W, 85W-90	10°F (-12°C)*
90	35°F (2°C)

* Maximum temperature for Brookfield Viscosity¹ of 150,000 centipoise (cP)² per SAE J306 MAR85

¹ Brookfield Viscosity—apparent viscosity as determined under ASTM D 2983

² 150,000 cP determined to provide sufficient low temperature lube properties for Auburn Gear Power Wheels

Lubrication Data

1. Type

In normal applications use an extreme pressure lubricant API-GL-5 approved. Auburn Gear recommends SAE 80W-90 grades of lube under normal climate and operating conditions. See chart below. For severe or abnormal applications with special requirements, consult either Auburn Gear or a lubricant manufacturer for further assistance.

2. Change Interval

Initial lubrications change after 50 hours of operation. Subsequent changes every 1,000 hours or yearly, whichever comes first.

3. Lube Temperature

Continuous operating temperatures of 160°F are allowable. Maximum intermittent temperature recommended is 200°F.

4. Amount of Lube

The unit should be half full when mounted horizontal. Lube levels for other mounts will vary. Consult Auburn Gear for details.

5. Shaft or Spindle Up Mounting

If mounting unit vertically with shaft or spindle up, special provisions apply to ensure adequate lubrication of output bearings. Consult Auburn Gear.

Power Wheel Planetary Drives are shipped without lubricant and must be filled to the proper level prior to start-up.

Warranty Information

Power Wheel® Warranty

Seller warrants to Purchaser that its Power Wheel® planetary gear products are free from defects in material and workmanship under normal use and service for a period of one year from the date the product is shown to have been placed into operation by original user or for two years from date of shipment from seller's plant, whichever shall first occur.

Seller's obligation under this warranty is expressly limited to the repair or replacement at its option, of the Power Wheel which is returned with a written claim of defect f.o.b. seller's factory, Auburn, Indiana, U.S.A., and which is determined by Seller to be defective.

THIS IS THE SOLE AND ONLY WARRANTY OF SELLER AND NO OTHER WARRANTY IS APPLICABLE, EITHER EXPRESSED OR IMPLIED, IN FACT OR BY LAW, INCLUDING ANY WARRANTY AS TO MERCHANTABILITY OR FITNESS FOR A PARTICULAR USE OR PURPOSE.

The sole and only remedy in regard to any defective Power Wheel shall be the repair or replacement thereof herein provided, and seller shall not be liable for any consequential, special, incidental, or punitive damages, losses or expenses resulting from or caused by any defects.

Auburn Gear, LLC
Auburn, Indiana, U.S.A.



Providing Technology, Quality, & Customer Support Around the Globe



400 E. Auburn Drive • Auburn, IN 46706 USA
260.925.3200
www.AuburnGear.com

*All specifications and data contained herein are nominal and subject to change without notice.
Specific applications should be referred to Auburn Gear for current information.*